

专业工具行业，把品质带向全球！
Professional tool industry, bringing quality to the world!



PINCHEN TOOLS



玉环品臣液压工具有限公司
YUHUAN PINCHEN HYDRAULIC TOOLS CO., LTD.

地址：浙江·台州·玉环市玉城街道产业城 邮编：317605
电话：0576-81749211 / 13566839281 传真：0576-81749211

Add: Yucheng Street Industrial City, Yuhuan County, Taizhou City,
Zhejiang, P.R. China Post Code: 317605
Tel: 0576-81749211/013566839281 Fax: 0576-81749211

E-mail: pc@hotpctools.com
<http://www.hotpctools.com> pinchenyy.cn.allbaba.com

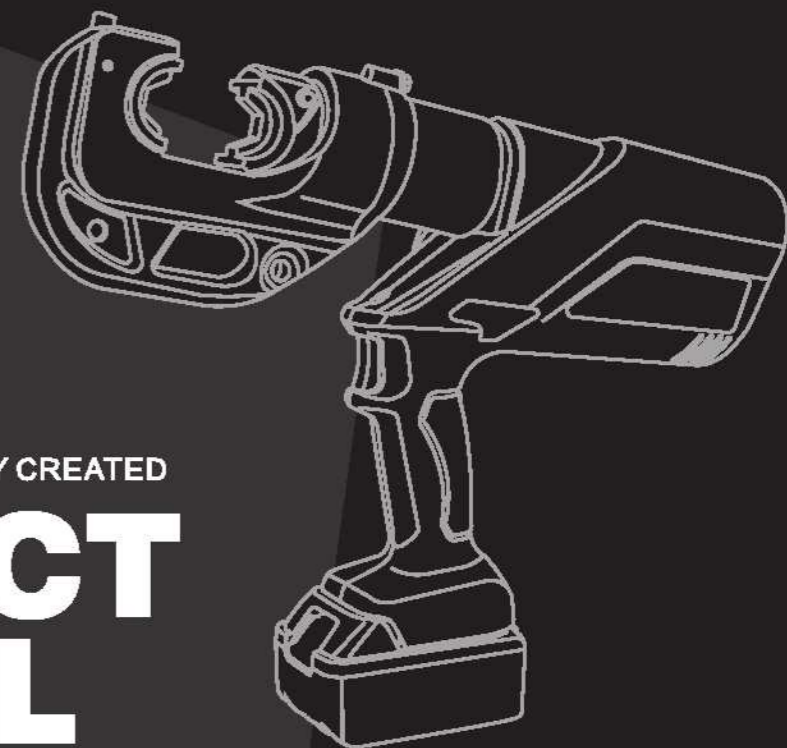
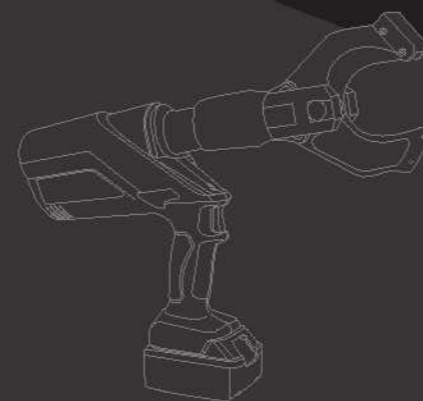

HYDRAULIC TOOLS

EXCELLENT QUALITY PAINSTAKINGLY CREATED

PRODUCT
MANUAL

YUHUAN PINCHEN HYDRAULIC TOOLS CO., LTD.

2023-24
CATALOG



PINCHEN

专业工具行业，把品质带向全球！

公司简介 COMPANY PROFILE

玉环品臣液压工具有限公司是一家从事液压工具、电力工具的开发、生产、销售于一体的多元化企业。由于本公司不断追求高水平、高标准的质量意识，在服务上不断超越客户的期望，并以超前的创新思想意识，先进的生产工艺和相对的价格优势在国内外赢得了很高的信誉，并占有一定的市场率。

本公司始终坚持以“质量为生命，信誉为支柱，力创国际品牌”的指导方针。不断奋发努力，让“品臣”品牌享誉全球。真诚地希望与更多的国内外朋友结识，谋求平等互利的贸易合作，共同促进世界经济繁荣昌盛。

企业经营理念以品牌形象为中心，以人才管理为依托，以科技创新、品质、服务为基点，锐意进取、坚忍不拔、力创业界先锋、企业标准创新、真诚信用、合理利润、良好的合作精神站在客户的立场为客户着想。

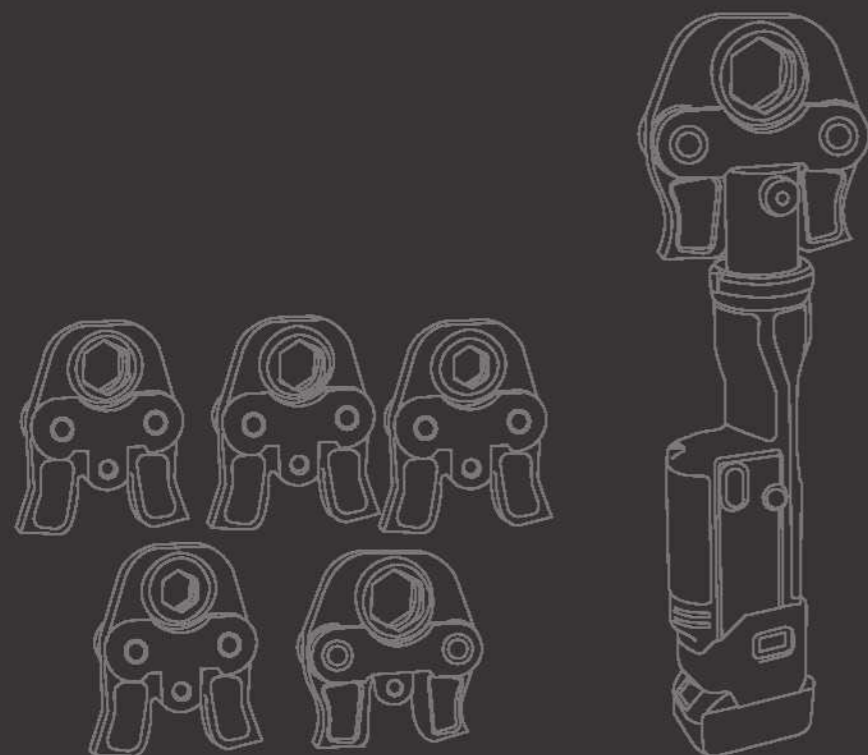

与时俱进 保持创新
KEEP PACE WITH THE TIMES
KEEP INNOVATING



CATALOGUE

目录

01

- **插电式液压工具**
HYDRAULIC TOOLS WITH POWER CORD
01-05
- **充电式液压工具**
BATTERY POWERED HYDRAULIC TOOLS
06-20
- **整体/分体式液压钳**
HYDRAULIC CRIMPING TOOLS
21-34
- **液压拉马**
HYDRAULIC FULLER
35-36
- **电动液压钢筋剪**
ELECTRIC HYDRAULIC STEEL CUTTER
37

02

- **电动钢筋弯曲机**
HYDRAULIC STEEL BENDING MACHINE
38
- **液压钢筋剪**
HYDRAULIC REBAR CUTTER
39-42
- **液压钢筋弯曲机**
HYDRAULIC STEEL BENDING MACHINE
43-44
- **螺帽破切器**
HYDRAULIC NUT CUTTER
45-46
- **液压开孔器**
HYDRAULIC HOLE OPENER
47-50
- **电动液压冲孔机**
HYDRAULIC PUNCHING TOOLS
51-53
- **电动角钢加工机**
ELECTRIC ANGLE IRON PROCESSOR
54-56

03

- **液压冲孔机**
HYDRAULIC PUNCHING TOOLS
57-59
- **液压切排机**
HYDRAULIC BRASS CUTTER
60
- **液压弯排机**
HYDRAULIC BENDING MACHINE
61-62
- **液压角钢加工机**
HYDRAULIC ANGLE-IRON PROCESSOR
63-64
- **母线加工机**
HYDRAULIC CRIMPING TOOLS
65-66
- **液压母线加工机组合**
BUSBAR PROCESSING MACHINE
67-68

04

- **液压弯管机**
HYDRAULIC PIPE BENDER
69-70
- **液压铆钉机**
HYDRAULIC RIVET MACHINE
70
- **手动/电动液压泵**
HYDRAULIC PUMP
71-76
- **液压千斤顶**
HYDRAULIC CYLINDER
77-80

05

- **法兰扩张器/消防设备**
FLANGE EXPANDER & FIRE EQUIPMENT
81-82
- **液压线缆剪**
HYDRAULIC CABLE CUTTER
83-84
- **棘轮线缆剪**
RATCHET CABLE CUTTER
85-89
- **长臂式手动电缆剪刀**
LONG ARM TYPE MANUAL CABLE SCISSORS
90
- **剥线钳**
WIRE STRIPPING PLIERS
91-92
- **机械式液压钳**
MECHANICAL CRIMPING TOOLS
93-94

06

- **管道连接工具**
PIPE CONNECTION TOOL
95-96
- **试压泵**
PRESSURE TEST PUMP
97-98
- **液压扭矩扳手**
HYDRAULIC TORQUE WRENCH
99
- **电力工具&液压工具配件**
ELECTRIC POWER TOOL & HYDRAULIC TOOL ACCESSORIES
100-102

插电式液压工具

HYDRAULIC TOOLS WITH POWER CORD



插电式液压工具

HYDRAULIC TOOLS WITH POWER CORD

产品特点:

- 可快速启动, 压接头可360度旋转
- 电机动力足控制可调, 可快速停止, 用户安全性高
- 无极调速开关, 无极变速控制活塞速度, 快慢自由调节
- 压接完全后可以按回油开关复位
- 加厚型油缸, 压接出力大

FEATURES:

- It can be started quickly, and the pressure joint can be rotated 360 degrees
- Motor power foot control is adjustable, can be stopped quickly, user safety is high
- Stepless speed control switch, stepless variable speed control piston speed, free adjustment of speed
- After the crimping is complete, you can press the oil return switch to reset
- Thickened cylinder, large crimping output



02-300 插电式电动液压钳

技术参数 TECHNICAL DATA:	
出力(Crimping force):	60KN
行程(Stroke):	17mm
压接范围(Crimping range):	10-300mm ²
压接一次时间(Crimping cycle):	3-6S(depend on the size of cable)
电压(Voltage):	220V
电机功率(Motor Power):	1800/2000W
电机转速(Motor Speed):	0-5000r/min
重量(Weight):	10Kg
配件ACCESSORIES:	
模具(Crimping die):	10, 16, 25, 36, 50, 70, 95, 120, 150, 185, 240, 300mm ²

产品特点:

- 可快速启动, 压接头可360度旋转
- 电机动力足控制可调, 可快速停止, 用户安全性高
- 无极调速开关, 无极变速控制活塞速度, 快慢自由调节
- 压接完全后可以按回油开关复位
- 加厚型油缸, 压接出力大

FEATURES:

- It can be started quickly, and the pressure joint can be rotated 360 degrees
- Motor power foot control is adjustable, can be stopped quickly, user safety is high
- Stepless speed control switch, stepless variable speed control piston speed, free adjustment of speed
- After the crimping is complete, you can press the oil return switch to reset
- Thickened cylinder, large crimping output



02-400 插电式电动液压钳

技术参数 TECHNICAL DATA:	
出力(Crimping force):	120KN
行程(Stroke):	38mm
压接范围(Crimping range):	10-400mm ²
压接一次时间(Crimping cycle):	8-16S(depend on the size of cable)
电压(Voltage):	220V
电机功率(Motor Power):	1800/2000W
电机转速(Motor Speed):	0-5000r/min
重量(Weight):	13Kg
配件ACCESSORIES:	
模具(Crimping die):	10, 16, 25, 35, 50, 70, 95, 120, 150, 185, 240, 300, 400mm ²

产品特点:

- 一个全能王即可完成压接, 剪切和冲孔。
- 用于铠装或非铠装铝质和铜质导线的各种切断模。
- DIN导轨冲孔模具
- 用于螺杆和DIN导轨剪切的特殊切断模

FEATURES:

- The all-in-one multi function tool can do the crimping, cutting, and punching.
- Use for cutting different type mould of the armour or unarmour aluminum or copper wire
- DIN guide rail punching mould
- Use for cut the special cutting mould of the screw and DIN guide rail

全能王 ALL-IN-ONE



集多种功能于一身



02-60UNV 插电式电动全能王

技术参数 TECHNICAL DATA:	
出力(Crimping force):	60KN
行程(Stroke):	42mm
压接范围(Crimping range):	16-300mm ²
剪切范围(Cutting range):	Φ45mm(Cu/Al and armoured cable)
冲孔范围(Punching range):	Φ22.5-Φ81.5mm
电压(Voltage):	220V
电机功率(Motor Power):	1800/2000W
电机转速(Motor Speed):	0-6000r/min
重量(Weight):	20Kg
配件ACCESSORIES:	
压接模具(Crimping die):	16, 26, 36, 50, 70, 95, 120, 150, 185, 240, 300mm ²
冲孔模具/C组(Punches&die/Type C):	22.5, 28.3, 34.6, 43.2, 49.8, 81.5mm ²
刀片(Blade):	1付 (set)
压接适配器(Adapter for crimping):	1套 (set)
冲孔适配器(Adapter for punching):	1套 (set)
3/4", 16UN拉杆(3/4", 16UN Draw stud):	1根 (pc)
7/16" 20UN拉杆(7/16" 20UN Draw stud):	1根 (pc)



- 压接接头(Crimping head)
 - 剪切刀头(Cutting knife)
 - 冲孔头(Punching head)
- 铜压接端子(Copper head): 16-300mm²
铝压接端子(Aluminum head): 10-240mm²
- 剪切范围(Cutting range): Φ45mm铜铝线和铠装铝线、铜线或铝线、铜线或铝线铠装线
圆钢: 3.6mm以下软钢板
冲孔范围(punching range): Φ22.5-81.5mm
圆钢: 3.6mm以下软钢板

插电式液压工具

HYDRAULIC TOOLS WITH POWER CORD



插电式液压工具

HYDRAULIC TOOLS WITH POWER CORD

产品特点:

- 高品质刀片, 开口式设计, 提高剪切效率
- 电机动力足控制可调, 可快速停止, 用户安全性高
- 无极调速开关, 无极变速控制活塞速度, 快慢自由调节
- 压接完全后可以按回油开关复位
- 加厚型油缸, 剪切出力大

FEATURES:

- High-quality blades, open-ended design, improve cutting efficiency
- Motor power foot control is adjustable, can be stopped quickly, user safety is high
- Stepless speed control switch, stepless variable speed control piston speed, free adjustment of speed
- After the crimping is complete, you can press the oil return switch to reset
- Thickened oil cylinder, high shear output



0Z-30 插电式电动线缆剪

Electric cable cutter

技术参数 TECHNICAL DATA:	
出力(Crimping force):	6T
剪切范围(Cutting range):	Φ30以下铜芯铝绞线
剪切一次时间(Cutting cycle):	3-8S(depend on the size of cable)
电压(Voltage):	220V
电机功率(Motor Power):	1800/2000W
电机转速(Motor Speed):	0-5000r/min
重量(Weight):	10Kg



0Z-50 插电式电动线缆剪

Electric cable cutter

技术参数 TECHNICAL DATA:	
出力(Crimping force):	6T
剪切范围(Cutting range):	Φ60以下铜铝线和铠装电缆
剪切一次时间(Cutting cycle):	3-8S(depend on the size of cable)
电压(Voltage):	220V
电机功率(Motor Power):	1800/2000W
电机转速(Motor Speed):	0-5000r/min
重量(Weight):	10Kg



0Z-65 插电式电动线缆剪

Electric cable cutter

技术参数 TECHNICAL DATA:	
出力(Crimping force):	6T
剪切范围(Cutting range):	Φ66以下铜铝线和铠装电缆
剪切一次时间(Cutting cycle):	3-8S(depend on the size of cable)
电压(Voltage):	220V
电机功率(Motor Power):	1800/2000W
电机转速(Motor Speed):	0-5000r/min
重量(Weight):	12Kg



0Z-85 插电式电动线缆剪

Electric cable cutter

技术参数 TECHNICAL DATA:	
出力(Crimping force):	6T
剪切范围(Cutting range):	Φ86以下铜铝线和铠装电缆
剪切一次时间(Cutting cycle):	5-13S(depend on the size of cable)
电压(Voltage):	220V
电机功率(Motor Power):	1800/2000W
电机转速(Motor Speed):	0-5000r/min
重量(Weight):	14Kg

产品特点:

- 电机动力足控制可调, 可快速停止, 用户安全性高
- 无极调速开关, 无极变速控制活塞速度, 快慢自由调节
- 压接完全后可以按回油开关复位
- 加厚型油缸, 压管出力大

FEATURES:

- Motor power foot control is adjustable, can be stopped quickly, user safety is high
- Stepless speed control switch, stepless variable speed control piston speed, free adjustment of speed
- After the crimping is complete, you can press the oil return switch to reset
- Thickened oil cylinder, high shear output

0Z-1525/1632 插电式电动压管钳

Electric pressure pipe wrench

技术参数 TECHNICAL DATA:	
出力(Crimping force):	6T
压接范围(Crimping range):	压接不锈钢管、铝接管
电压(Voltage):	220V
电机功率(Motor Power):	1000/1180W
电机转速(Motor Speed):	0-3000r/min
重量(Weight):	10Kg
配件 ACCESSORIES:	
模具(Crimping dies):	Crimping dies for SV type: 15mm, 20mm, 25mm Crimping dies for U type: 16mm, 20mm, 25mm, 32mm Crimping dies for TH type: 16mm, 20mm, 26mm, 32mm



产品特点:

- 电机动力足控制可调, 可快速停止, 用户安全性高
- 无极调速开关, 无极变速控制活塞速度, 快慢自由调节
- 压接完全后可以按回油开关复位
- 加厚型油缸, 压管出力大

FEATURES:

- Motor power foot control is adjustable, can be stopped quickly, user safety is high
- Stepless speed control switch, stepless variable speed control piston speed, free adjustment of speed
- After the crimping is complete, you can press the oil return switch to reset
- Thickened oil cylinder, high shear output

0Z-1550 插电式电动压管钳

Electric pressure pipe wrench

技术参数 TECHNICAL DATA:	
出力(Crimping force):	6T
压接范围(Crimping range):	压接DN15-DN60不锈钢管
电压(Voltage):	220V
电机功率(Motor Power):	1000/1180W
电机转速(Motor Speed):	0-3000r/min
重量(Weight):	10Kg
配件 ACCESSORIES:	
模具(Crimping dies):	DN15, DN20, DN25, DN32, DN40, DN50



插电式液压工具

HYDRAULIC TOOLS WITH POWER CORD



充电式液压工具

BATTERY POWERED HYDRAULIC TOOLS

产品特点:

- 可快速启动, 开孔能力大, 退料方便
- 电机动力足控制可调, 可快速停止, 用户安全性高
- 无极调速开关, 无极变速控制活塞速度, 快慢自由调节
- 压接完全后可以按回油开关复位

FEATURES:

- Quick start, large hole opening capacity, easy to return
- Motor power foot control is adjustable, can be stopped quickly, user safety is high
- Stepless speed control switch, stepless variable speed control piston speed, free adjustment of speed
- After the crimping is complete, you can press the oil return switch to reset



07-25 插电式电动桥梁开孔器

Electric bridge hole opener

技术参数 TECHNICAL DATA:	
出力(Crimping force):	6T
喉深(Depth of throat):	70mm (模具中心到量面距离)
开孔能力(Punching capacity):	不锈钢厚度(Stainless steel) ≤ 1mm 铁板厚度(Iron steel) ≤ 1mm
电压(Voltage):	220V
电机功率(Motor Power):	1000/1180W
电机转速(Motor Speed):	0-3000r/min
重量(Weight):	8.0Kg
配件ACCESSORIES:	
模具(Crimping dies):	Φ16, Φ20, Φ22, Φ25, Φ28, Φ32

07-18 插电式电动冲孔机

Electric punching machine

技术参数 TECHNICAL DATA:	
出力(Crimping force):	6T
喉深(Depth of throat):	33mm (模具中心到量面距离)
开孔能力(Punching capacity):	铜铝棒(Cu/Al rod) ≤ 10mm 铁板(Iron steel) ≤ 8mm 槽钢(Channel steel)
电压(Voltage):	220V
电机功率(Motor Power):	1000/1180W
电机转速(Motor Speed):	0-3000r/min
重量(Weight):	20.66Kg
配件ACCESSORIES:	
模具(Crimping dies):	Φ10.5, Φ13.5, Φ17.5, Φ20.5

产品特点:

- 可快速启动, 高强度特殊切片, 坚固耐用
- 电机动力足控制可调, 可快速停止, 用户安全性高
- 无极调速开关, 无极变速控制活塞速度, 快慢自由调节
- 压接完全后可以按回油开关复位
- 加厚型油缸, 破切螺帽出力大

FEATURES:

- Quick start, high-strength special cutting blade, strong and durable
- Motor power foot control is adjustable, can be stopped quickly, user safety is high
- Stepless speed control switch, stepless variable speed control piston speed, free adjustment of speed
- After the crimping is complete, you can press the oil return switch to reset
- Thickened oil cylinder, large output of broken nut

07-24 插电式电动螺帽破切器

Electric nut cutter

技术参数 TECHNICAL DATA:	
出力(Crimping force):	6T
螺帽范围(Dismountable nut):	M16-M24
电压(Voltage):	220V
电机功率(Motor Power):	1000/1180W
电机转速(Motor Speed):	0-3000r/min
重量(Weight):	10Kg



产品特点:

- 压接能力大 (达300mm²)
- 可顶部翻转型压接头, 可旋转360°
- 紧凑型压接头, 适用空间狭小的工作环境。

FEATURES:

- Big crimping(maxim 300mm²).
- The crimping head rotated 360°.
- Compact crimping head, suit for the narrow space working.

EZ-300 充电式液压钳

Battery powered crimping tools

技术参数 TECHNICAL DATA:	
出力(Crimping force):	60KN
行程(Stroke):	17mm
压接范围(Crimping range):	10-300mm ²
压接次数(Crimp/charge):	320times(Cu 150mm ²)
压接一次时间(Crimping cycle):	3-8S(depend on the size of cable)
电池电压(Voltage):	18V
电池容量(Capacity):	5.0Ah
充电时间(Charging time):	2 hours
配件ACCESSORIES:	
模具(Crimping dies):	10, 16, 25, 35, 50, 70, 95, 120, 150, 185, 240, 300mm ²
电池(Battery):	2块(pcs)
充电器(Charger):	1个(pc)
油缸密封圈(Sealing ring of cylinder):	1套(set)
安全阀密封圈(Sealing ring of valve):	1套(set)



产品特点:

- 压接能力大 (达400mm²)
- C型压接头, 架空作业时的理想工具, 可旋转360°
- 宽压接, 重量轻。

FEATURES:

- Big crimping (maxim 400mm²).
- C type crimping head, the ideal tool for the aerial work, the crimping head rotated 360°.
- Wider crimping, lower weight.

EZ-400 充电式液压钳

Battery powered crimping tools

技术参数 TECHNICAL DATA:	
出力(Crimping force):	120KN
行程(Stroke):	32mm
压接范围(Crimping range):	10-400mm ²
压接次数(Crimp/charge):	120times(Cu 150mm ²)
压接一次时间(Crimping cycle):	6-18S(depend on the size of cable)
电池电压(Voltage):	18V
电池容量(Capacity):	5.0Ah
充电时间(Charging time):	2 hours
配件ACCESSORIES:	
模具(Crimping dies):	10, 16, 25, 35, 50, 70, 95, 120, 150, 185, 240, 300, 400mm ²
电池(Battery):	2块(pcs)
充电器(Charger):	1个(pc)
油缸密封圈(Sealing ring of cylinder):	1套(set)
安全阀密封圈(Sealing ring of valve):	1套(set)



充电式液压工具

BATTERY POWERED HYDRAULIC TOOLS



充电式液压工具

BATTERY POWERED HYDRAULIC TOOLS

产品特点:

- 压接能力大 (达630mm²)。
- 可顶部翻转型压接头, 可旋转360°。
- 紧凑型压接头, 适用空间狭小的工作环境。

FEATURES:

- Big crimping(maxim 630mm²).
- The crimping head rotated 360°.
- Compact crimping head, suit for the narrow space working.



EZ-630 充电式液压钳

Battery powered crimping tools

技术参数 TECHNICAL DATA:	
出力(Crimping force):	200KN
行程(Stroke):	20mm
压接范围(Crimping range):	25-630mm ²
压接次数(Crimp/charger):	120times(Cu 150mm ²)
压接一次时间(Crimping cycle):	6-18S(depend on the size of cable)
电池电压(Voltage):	18V
电池电容量(Capacity):	5.0Ah
充电时间(Charging time):	2 hours
配件ACCESSORIES:	
模具(Crimping die):	25,35,50,70,85,120,150,185,240,300,400,630mm ²
电池(Battery):	2块(pcs)
充电器(Charger):	1个(pc)
油缸密封圈(Sealing ring of cylinder):	1套(set)
安全阀密封圈(Sealing ring of valve):	1套(set)

产品特点:

- 压接能力大 (达240mm²)。
- 可顶部翻转型压接头, 可旋转360°。
- 紧凑型压接头, 适用空间狭小的工作环境。

FEATURES:

- Big crimping(maxim 240mm²).
- The crimping head rotated 360°.
- Compact crimping head, suit for the narrow space working.



ES-240 充电式液压钳

Battery powered crimping tools

技术参数 TECHNICAL DATA:	
出力(Crimping force):	50KN
行程(Stroke):	16mm
压接范围(Crimping range):	16-240mm ²
压接次数(Crimp/charger):	170times(Cu 150mm ²)
压接一次时间(Crimping cycle):	3-8S(depend on the size of cable)
电池电压(Voltage):	18V
电池电容量(Capacity):	4.0Ah
充电时间(Charging time):	2 hours
配件ACCESSORIES:	
模具(Crimping die):	16,25,35,50,70,85,120,150,185,240mm ²
电池(Battery):	2块(pcs)
充电器(Charger):	1个(pc)
油缸密封圈(Sealing ring of cylinder):	1套(set)
安全阀密封圈(Sealing ring of valve):	1套(set)

产品特点:

- 压接能力大 (达300mm²)。
- 可顶部翻转型压接头, 可旋转360°。
- 紧凑型压接头, 适用空间狭小的工作环境。

FEATURES:

- Big crimping(maxim 300mm²).
- The crimping head rotated 360°.
- Compact crimping head, suit for the narrow space working.

ES-300 充电式液压钳

Battery powered crimping tools

技术参数 TECHNICAL DATA:	
出力(Crimping force):	50KN
行程(Stroke):	17mm
压接范围(Crimping range):	16-300mm ²
压接次数(Crimp/charger):	170times(Cu 150mm ²)
压接一次时间(Crimping cycle):	3-8S(depend on the size of cable)
电池电压(Voltage):	18V
电池电容量(Capacity):	4.0Ah
充电时间(Charging time):	2 hours
配件ACCESSORIES:	
模具(Crimping die):	16,25,35,50,70,85,120,150,185,240,300mm ²
电池(Battery):	2块(pcs)
充电器(Charger):	1个(pc)
油缸密封圈(Sealing ring of cylinder):	1套(set)
安全阀密封圈(Sealing ring of valve):	1套(set)



产品特点:

- 压接能力大 (达400mm²)。
- C型压接头, 架空作业时的理想工具, 可旋转360°。
- 宽压接, 重量轻。

FEATURES:

- Big crimping(maxim 400mm²).
- C type crimping head, the ideal tool for the aerial work, the crimping head rotated 360°.
- Wider crimping, lower weight.

ES-400 充电式液压钳

Battery powered crimping tools

技术参数 TECHNICAL DATA:	
出力(Crimping force):	120KN
行程(Stroke):	42mm
压接范围(Crimping range):	16-400mm ²
压接次数(Crimp/charger):	120times(Cu 150mm ²)
压接一次时间(Crimping cycle):	6-18S(depend on the size of cable)
电池电压(Voltage):	18V
电池电容量(Capacity):	4.0Ah
充电时间(Charging time):	2 hours
配件ACCESSORIES:	
模具(Crimping die):	16,25,35,50,70,85,120,150,185,240,300,400mm ²
电池(Battery):	2块(pcs)
充电器(Charger):	1个(pc)
油缸密封圈(Sealing ring of cylinder):	1套(set)
安全阀密封圈(Sealing ring of valve):	1套(set)



充电式液压工具

BATTERY POWERED HYDRAULIC TOOLS



充电式液压工具

BATTERY POWERED HYDRAULIC TOOLS

产品特点:

- 强劲大容量18V锂电池驱动,用途广泛
- 握把符合人体工程学,操作舒适

FEATURES:

- Powerful and high-capacity 18V lithium battery drive, versatile
- Ergonomic grip and comfortable operation

EW-50X 直立式充电式冷压钳

技术参数 TECHNICAL DATA:	
出力(Crimping force):	16KN
行程(Stroke):	17mm
压接范围(Crimping range):	0.5-50mm ² (TG-JT型即管型紫铜的端子) 0.5-10mm ² (TO-TU型即圆形、叉形端子) 0.8-8mm ² (TO-JTK TU-JTK型即圆形、叉形端子)
电池电压(Voltage):	18V
电池容量(Capacity):	2.0Ah
充电时间(Charging time):	2hours
产品尺寸(Size):	长262×宽112×高73mm
重量(Weight):	1Kg
配件ACCESSORIES:	
模具(Crimping dies):	16,25,35,50,70,95,120,150,185,240,300mm ²
电池(Battery):	2块(pcs)
充电器(Charger):	1个(pc)
油缸密封圈(Sealing ring of cylinder):	1套(set)
安全阀密封圈(Sealing ring of valve):	1套(set)



产品特点:

- 压接剪切二合一 钳头可350度旋转
- 强劲大容量18V锂电池驱动,用途广泛
- 握把符合人体工程学,操作舒适

FEATURES:

- Two-in-one crimping and cutting pliers head can rotate 350 degrees
- Powerful and high-capacity 18V lithium battery drive, versatile
- Ergonomic grip and comfortable operation

ES-300C 充电式液压钳+线剪

技术参数 TECHNICAL DATA:	
出力(Crimping force):	50KN
行程(Stroke):	17mm
压接范围(Crimping range):	16-300mm ²
剪切范围(Cutting range):	Φ30mm(Cu/Al and armoured cable)
电池电压(Voltage):	18V
电池容量(Capacity):	4.0Ah
充电时间(Charging time):	2hours
重量(Weight):	3.5Kg
配件ACCESSORIES:	
模具(Crimping dies):	16,25,35,50,70,95,120,150,185,240,300mm ²
电池(Battery):	2块(pcs)
充电器(Charger):	1个(pc)
油缸密封圈(Sealing ring of cylinder):	1套(set)
安全阀密封圈(Sealing ring of valve):	1套(set)



产品特点:

- 压接剪切二合一 钳头可350度旋转
- 强劲大容量18V锂电池驱动,用途广泛
- 握把符合人体工程学,操作舒适

FEATURES:

- Two-in-one crimping and cutting pliers head can rotate 350 degrees
- Powerful and high-capacity 18V lithium battery drive, versatile
- Ergonomic grip and comfortable operation



EZ-300/45 充电式液压钳+线剪

技术参数 TECHNICAL DATA:	
出力(Crimping force):	60KN
行程(Stroke):	50mm
压接范围(Crimping range):	10-300mm ²
剪切范围(Cutting range):	Φ45mm(Cu/Al and armoured cable)
电池电压(Voltage):	18V
电池容量(Capacity):	5.0Ah
充电时间(Charging time):	1.5-5 hours
重量(Weight):	4.75Kg
配件ACCESSORIES:	
模具(Crimping dies):	10,16,25,35,50,70,95,120,150,185,240,300mm ²
电池(Battery):	2块(pcs)
充电器(Charger):	1个(pc)
油缸密封圈(Sealing ring of cylinder):	1套(set)
安全阀密封圈(Sealing ring of valve):	1套(set)



产品特点:

- 压接剪切二合一 钳头可350度旋转
- 强劲大容量18V锂电池驱动,用途广泛
- 握把符合人体工程学,操作舒适

FEATURES:

- Two-in-one crimping and cutting pliers head can rotate 350 degrees
- Powerful and high-capacity 18V lithium battery drive, versatile
- Ergonomic grip and comfortable operation



EZ-400/55 充电式液压钳+线剪

技术参数 TECHNICAL DATA:	
出力(Crimping force):	120KN
行程(Stroke):	38mm
压接范围(Crimping range):	18-400mm ²
剪切范围(Cutting range):	Φ55mm(Cu/Al and armoured cable)
电池电压(Voltage):	18V
电池容量(Capacity):	5.0Ah
充电时间(Charging time):	2 hours
配件ACCESSORIES:	
模具(Crimping dies):	10,16,25,35,50,70,95,120,150,185,240,300,400mm ²
电池(Battery):	2块(pcs)
充电器(Charger):	1个(pc)
密封件(Sealing element):	1套(set)



充电式液压工具

BATTERY POWERED HYDRAULIC TOOLS



卓越品质 精心所制

产品特点:

- 压接剪切二合一 钳头可350度旋转
- 强劲大容量18V锂电池驱动, 用途广泛
- 握把符合人体工程学, 操作舒适



FEATURES:

- Two-in-one crimping and cutting pliers head can rotate 350 degrees
- Powerful and high-capacity 18V lithium battery drive, versatile
- Ergonomic grip and comfortable operation

EZ-400/85C 充电式液压钳+线绳剪

技术参数 TECHNICAL DATA:	
出力(Crimping force):	120KN
行程(Stroke):	38mm
压接范围(Crimping range):	16-400mm ²
剪切范围(Cutting range):	Φ85mm(Cu/Al and armoured cable)
电池电压(Voltage):	18V
电池容量(Capacity):	5.0Ah
充电时间(Charging time):	2 hours
配件ACCESSORIES:	
模具(Crimping dies):	16,25,35,50,70,95,120,150,185,240,300,400mm ²
电池(Battery):	2块(pcs)
充电器(Charger):	1个(pc)
密封件(Sealing element):	1套(set)



产品特点:

- 压接剪切二合一 钳头可350度旋转
- 强劲大容量18V锂电池驱动, 用途广泛
- 握把符合人体工程学, 操作舒适



FEATURES:

- Two-in-one crimping and cutting pliers head can rotate 350 degree
- Powerful and high-capacity 18V lithium battery drive, versatile
- Ergonomic grip and comfortable operation

EZ-400/105C 充电式液压钳+线绳剪

技术参数 TECHNICAL DATA:	
出力(Crimping force):	120KN
行程(Stroke):	38mm
压接范围(Crimping range):	16-400mm ²
剪切范围(Cutting range):	Φ105mm(Cu/Al and armoured cable)
电池电压(Voltage):	18V
电池容量(Capacity):	5.0Ah
充电时间(Charging time):	2 hours
配件ACCESSORIES:	
模具(Crimping dies):	16,25,35,50,70,95,120,150,185,240,300,400mm ²
电池(Battery):	2块(pcs)
充电器(Charger):	1个(pc)
密封件(Sealing element):	1套(set)



安全/ 高效/ 可靠/ 轻便/

SAFETY/ HIGH EFFICIENCY/ TRUSTFUL/ EASIER/



产品特点:

- 利用直流电压驱动马达, 以机械棘轮式进退刀带动剪切
- 剪切能力快速, 轻便又省力
- 刀片采用合金钢材质, 皆经过硬化处理, 不轻易损坏

FEATURES:

- Drive the motor with DC voltage, and drive the shearing with mechanical ratcheting knife
- Fast cutting capacity, light and labor-saving
- The blade is made of alloy steel, which is hardened and not easily damaged

EC-50M/65M/75M 充电式棘轮线绳剪

技术参数 TECHNICAL DATA:	EC-50M	EC-65M	EC-75M
出力(Crimping force):	60KN	60KN	60KN
剪切范围(Cutting range):	Φ50mm(Cu/Al and armoured cable)	Φ65mm(Cu/Al and armoured cable)	Φ50mm(Cu/Al and armoured cable)
环境温度(Ambient temperature):	-10-40°C	-10-40°C	-10-40°C
电池电压(Voltage):	14.4V	14.4V	14.4V
电池容量(Capacity):	4.0Ah	4.0Ah	4.0Ah
充电时间(Charging time):	2 hours	2 hours	2 hours
配件ACCESSORIES:			
电池(Battery):	2块(pcs)	2块(pcs)	2块(pcs)
充电器(Charger):	1个(pc)	1个(pc)	1个(pc)
密封件(Sealing element):	1套(set)	1套(set)	1套(set)

注: 严禁剪切铜绞线之类刚性材质线缆
It is strictly forbidden to cut cables with rigid materials such as steel strands

充电式液压工具

BATTERY POWERED HYDRAULIC TOOLS



充电式液压工具

BATTERY POWERED HYDRAULIC TOOLS

产品特点:

- 超坚固设计
- 可剪切铠装铜质和铝质电缆
- 剪切头部可旋转360度
- 单手操作, 轻巧便捷
- 自动泄压、复位
- 必要时手动泄压

FEATURES:

- Tool head rotated 360 degrees
- Automatic pressure release
- LI-Ion battery powered



EZ-40 充电式线缆剪

Battery powered cable cutter

技术参数 TECHNICAL DATA:	
出力(Crimping force):	60KN
行程(Stroke):	50mm
剪切范围(Cutting range):	Φ40mm(Cu/Al and armoured cable)
剪切一次时间(Cutting cycle):	10-15S(depend on the size of cable)
电池电压(Voltage):	18V
电池电容量(Capacity):	5.0Ah
充电时间(Charging time):	2 hours
配件ACCESSORIES:	
电池(Battery):	2块(pcs)
充电器(Charger):	1个(pc)
密封件(Sealing element):	1套(set)

产品特点:

- 超坚固设计
- 可剪切铠装铜质和铝质电缆
- 剪切头部可旋转360度
- 单手操作, 轻巧便捷
- 自动泄压、复位
- 必要时手动泄压

FEATURES:

- Tool head rotated 360 degrees
- Automatic pressure release
- LI-Ion battery powered



EZ-55 充电式线缆剪

Battery powered cable cutter

技术参数 TECHNICAL DATA:	
出力(Crimping force):	120KN
行程(Stroke):	60mm
剪切范围(Cutting range):	Φ55mm(Cu/Al and armoured cable)
剪切一次时间(Cutting cycle):	10-15S(depend on the size of cable)
电池电压(Voltage):	18V
电池电容量(Capacity):	5.0Ah
充电时间(Charging time):	2 hours
配件ACCESSORIES:	
电池(Battery):	2块(pcs)
充电器(Charger):	1个(pc)
密封件(Sealing element):	1套(set)

产品特点:

- 超坚固设计
- 可剪切铠装铜质和铝质电缆
- 剪切头部可旋转360度
- 单手操作, 轻巧便捷
- 自动泄压、复位
- 必要时手动泄压

FEATURES:

- Tool head rotated 360 degrees
- Automatic pressure release
- LI-Ion battery powered



EZ-50 充电式线缆剪

Battery powered cable cutter

技术参数 TECHNICAL DATA:	
出力(Crimping force):	60KN
行程(Stroke):	55mm
剪切范围(Cutting range):	Φ45mm(Cu/Al and armoured cable)
剪切一次时间(Cutting cycle):	10-15S(depend on the size of cable)
电池电压(Voltage):	18V
电池电容量(Capacity):	5.0Ah
充电时间(Charging time):	2 hours
配件ACCESSORIES:	
电池(Battery):	2块(pcs)
充电器(Charger):	1个(pc)
密封件(Sealing element):	1套(set)

产品特点:

- 超坚固设计
- 可剪切铠装铜质和铝质电缆
- 剪切头部可旋转360度
- 单手操作, 轻巧便捷
- 自动泄压、复位
- 必要时手动泄压

FEATURES:

- Tool head rotated 360 degrees
- Automatic pressure release
- LI-Ion battery powered



EZ-105 充电式线缆剪

Battery powered cable cutter

技术参数 TECHNICAL DATA:	
出力(Crimping force):	60KN
行程(Stroke):	90mm
剪切范围(Cutting range):	Φ105mm(Cu/Al and armoured cable)
剪切一次时间(Cutting cycle):	12-18S(depend on the size of cable)
电池电压(Voltage):	18V
电池电容量(Capacity):	5.0Ah
充电时间(Charging time):	2 hours
配件ACCESSORIES:	
电池(Battery):	2块(pcs)
充电器(Charger):	1个(pc)
密封件(Sealing element):	1套(set)

充电式液压工具

BATTERY POWERED HYDRAULIC TOOLS



充电式液压工具

BATTERY POWERED HYDRAULIC TOOLS

卓越品质 精心所制

卓越品质 精心所制

EZ-30C 充电式线缆剪

技术参数 TECHNICAL DATA:	
出力(Crimping force):	60KN
行程(Stroke):	30mm
剪切范围(Cutting range):	Φ30mm(Cu/Al and armoured cable)
剪切一次时间(Cutting cycle):	3-8S(depend on the size of cable)
电池电压(Voltage):	18V
电池容量(Capacity):	5.0Ah
充电时间(Charging time):	2 hours
配件ACCESSORIES:	
电池(Battery):	2块(pcs)
充电器(Charger):	1个(pc)
密封件(Sealing element):	1套(set)



EZ-105C 充电式线缆剪

技术参数 TECHNICAL DATA:	
出力(Crimping force):	120KN
剪切范围(Cutting range):	Φ85mm(Cu/Al and armoured cable)
剪切一次时间(Cutting cycle):	12-20S(depend on the size of cable)
电池电压(Voltage):	18V
电池容量(Capacity):	5.0Ah
充电时间(Charging time):	2 hours
配件ACCESSORIES:	
电池(Battery):	2块(pcs)
充电器(Charger):	1个(pc)
密封件(Sealing element):	1套(set)



EZ-65C 充电式线缆剪

技术参数 TECHNICAL DATA:	
出力(Crimping force):	60KN
剪切范围(Cutting range):	Φ65mm(Cu/Al and armoured cable)
剪切一次时间(Cutting cycle):	12-15S(depend on the size of cable)
电池电压(Voltage):	18V
电池容量(Capacity):	5.0Ah
充电时间(Charging time):	2 hours
配件ACCESSORIES:	
电池(Battery):	2块(pcs)
充电器(Charger):	1个(pc)
密封件(Sealing element):	1套(set)



EZ-120C 充电式线缆剪

技术参数 TECHNICAL DATA:	
出力(Crimping force):	250KN
剪切范围(Cutting range):	□110mm以下铜铝电缆, 高压3×400, 低压5×400以下电缆
剪切一次时间(Cutting cycle):	12-20S(depend on the size of cable)
电池电压(Voltage):	18V
电池容量(Capacity):	5.0Ah
充电时间(Charging time):	2 hours
配件ACCESSORIES:	
电池(Battery):	2块(pcs)
充电器(Charger):	1个(pc)
密封件(Sealing element):	1套(set)



EZ-85C 充电式线缆剪

技术参数 TECHNICAL DATA:	
出力(Crimping force):	60KN
剪切范围(Cutting range):	Φ70mm(Cu/Al and armoured cable)
剪切一次时间(Cutting cycle):	12-18S(depend on the size of cable)
电池电压(Voltage):	18V
电池容量(Capacity):	5.0Ah
充电时间(Charging time):	2 hours
配件ACCESSORIES:	
电池(Battery):	2块(pcs)
充电器(Charger):	1个(pc)
密封件(Sealing element):	1套(set)



EZ-135C 充电式线缆剪

技术参数 TECHNICAL DATA:	
出力(Crimping force):	250KN
剪切范围(Cutting range):	□120mm以下铜铝电缆, 高压3×500, 低压5×400以下电缆
剪切一次时间(Cutting cycle):	12-20S(depend on the size of cable)
电池电压(Voltage):	18V
电池容量(Capacity):	5.0Ah
充电时间(Charging time):	2 hours
配件ACCESSORIES:	
电池(Battery):	2块(pcs)
充电器(Charger):	1个(pc)
密封件(Sealing element):	1套(set)



充电式液压工具

BATTERY POWERED HYDRAULIC TOOLS



充电式液压工具

BATTERY POWERED HYDRAULIC TOOLS

产品特点:

- 操作简单、快速、安全
- 两段式液压系统, 无压力时快速推进, 压接接触后变速推进, 大幅缩短操作时间
- 10000次+寿命, 参照国际领先标准
- 自动复位, 压管完成后自动泄压, 活塞快速退回起始位置
- 压管半途出错时, 可通过手动复位键将活塞退回起始位置
- LED液晶显示屏显示使用温度, 使用次数、电池电量等信息
- 动力安全功能, 马达自动停止
- 体积更小更轻便, 符合人体工程学设计

FEATURES:

- Simple, fast, and safe in operation
- Two-stage hydraulic system, rapid propulsion without pressure, variable speed propulsion after compression contact, significantly shorten the operation time
- 10,000 times + life life, referring to the international leading standards
- Automatic reset, automatic pressure relief after the pressure pipe, and the piston quickly returns to the starting position
- When the pressure line is wrong, the piston can be returned to the starting position by manual reset key
- The LED LCD screen displays the use temperature, use times, battery level and other information
- Power safety function, the motor automatically stops
- Smaller and lighter, with an ergonomic design



HHYD-1532 充电式压管钳 Battery powered pipe wrench

技术参数 TECHNICAL DATA:	
出力(Crimping force):	1.9T
行程(Stroke):	30mm
电池饱和力(Battery saturation force):	120次压管(使用DN20不锈钢管件)
压管一次时间(Pressure tube time):	5-8S
电池电压(Voltage):	12V
电池电容量(Capacity):	1.5Ah
重量(Weight):	2.45Kg 口不含电池口模具口
配件ACCESSORIES:	
模具(Crimping die):	DN15, DN20, DN25
电池(Battery):	2块(pcs)
充电器(Charger):	1个(pc)
密封件(Sealing element):	1套(set)



适用于DN15-DN25的管道压接, 压接精准可靠, 连接处无论是密封性还是抗拉拔性, 均达到业界标准
标配DN15-DN25符合国际GB/T 19228 不锈钢管件的卡压式模具

产品特点:

- 头部可360度旋转, 双数双作用液压装置设计
- 当压接完成时电动机停止和自动回位, 在必要的情况下可手动回油
- 高性能锂电池, 一个开关可以控制所有工具
- PVC外壳强化机体不易破碎, 内设安全阀装置
- 自动断电功能, 产品不使用后, 系统会自动断电, 以免造成损失

FEATURES:

- The head can rotate 360 degrees, and the design of double-number double-acting hydraulic device
- When the crimping is completed, the motor stops and automatically returns, and the oil can be returned manually if necessary
- High-performance lithium battery, one switch can control all tools
- The PVC shell is reinforced and the body is not easily broken, and the safety valve device is built in
- Automatic power off function, the system will automatically power off after the product is not in use to avoid loss

EZ-1550 充电式压管钳 Battery powered pipe wrench

技术参数 TECHNICAL DATA:	
出力(Crimping force):	>40KN
行程(Stroke):	35mm
压接范围(Crimp range):	DN15-DN50薄壁不锈钢管
剪切一次时间(Cutting cycle):	5-8S(depend on the size of cable)
电池电压(Voltage):	18V
电池电容量(Capacity):	5.0Ah
充电时间(Charging time):	2 hours
配件ACCESSORIES:	
模具(Crimping die):	DN15, DN20, DN25, DN32, DN40, DN50
电池(Battery):	2块(pcs)
充电器(Charger):	1个(pc)
密封件(Sealing element):	1套(set)



产品特点:

- 头部可360度旋转, 双数双作用液压装置设计
- 当压接完成时电动机停止和自动回位, 在必要的情况下可手动回油
- 高性能锂电池, 一个开关可以控制所有工具
- PVC外壳强化机体不易破碎, 内设安全阀装置
- 自动断电功能, 产品不使用后, 系统会自动断电, 以免造成损失

FEATURES:

- The head can rotate 360 degrees, and the design of double-number double-acting hydraulic device
- When the crimping is completed, the motor stops and automatically returns, and the oil can be returned manually if necessary
- High-performance lithium battery, one switch can control all tools
- The PVC shell is reinforced and the body is not easily broken, and the safety valve device is built in
- Automatic power off function, the system will automatically power off after the product is not in use to avoid loss

ES-1550 充电式压管钳 Battery powered pipe wrench

技术参数 TECHNICAL DATA:	
出力(Crimping force):	50KN
行程(Stroke):	17mm
压接范围(Crimp range):	DN15-DN50薄壁不锈钢管
剪切一次时间(Cutting cycle):	3-8S(depend on the size of cable)
电池电压(Voltage):	18V
电池电容量(Capacity):	4.0Ah
充电时间(Charging time):	2 hours
配件ACCESSORIES:	
模具(Crimping die):	DN15, DN20, DN25, DN32, DN40, DN50
电池(Battery):	2块(pcs)
充电器(Charger):	1个(pc)
密封件(Sealing element):	1套(set)



充电式液压工具

BATTERY POWERED HYDRAULIC TOOLS



充电式液压工具

BATTERY POWERED HYDRAULIC TOOLS

产品特点:

- 电池余电及电压油压显示更直观
- 强劲大容量 18V 锂电池驱动, 用途广泛
- 握把符合人体工程学, 操作舒适
- 设有加油口, 易于维护

FEATURES:

- More intuitive display of battery power and voltage and oil pressure
- Powerful and high-capacity 18V lithium battery drive, versatile
- Ergonomic grip and comfortable operation
- With fuel filler, easy to maintain

ECH-AP18 充电式打孔机 Battery powered hole puncher

技术参数 TECHNICAL DATA:

出力(Crimping force):	130KN
喉深(Depth of throat):	33mm (模具中心到端面距离)
铜铝棒(Cu/Al rod):	≤10mm
铁板(Iron steel):	≤8mm
槽钢(Channel steel):	—
电池电压(Voltage):	18V
电池容量(Capacity):	3.0Ah
充电时间(Charging time):	45 minute

配件 ACCESSORIES:

模具(Crimping die):	Φ10.5, Φ13.5, Φ17.5, Φ20.5
电池(Battery):	2块(pcs)
充电器(Charger):	1个(pc)
密封件(Sealing element):	1套(set)



产品特点:

- C型工作头, 超宽工作范围
- 高强度铆接钳口, 锻打钳口一体成型, 铆接牢固, 小巧灵活顺手抗造耐用
- 电池余电及电压油压显示更直观
- 强劲大容量 18V 锂电池驱动, 用途广泛
- 握把符合人体工程学, 操作舒适舒适

FEATURES:

- C-type working head, super-wide working range
- High strength riveting pliers, forging pliers integrated molding, riveting, small, flexible and durable
- Battery residual power and voltage and oil pressure display is more intuitive
- Strong high capacity 18V lithium battery drive, widely used
- The grip is ergonomic and comfortable to operate

PPC-W 充电式液压铆钉机 Battery hydraulic rivets

技术参数 TECHNICAL DATA:

出力(Crimping force):	60KN
行程(Stroke):	35mm
工作范围(Working range):	风管法兰角钢 40×40×4 50×50×5
铆钉尺寸(Rivet size):	4×10 5×10
电池电压(Voltage):	18V
电池容量(Capacity):	5.0Ah
充电时间(Charging time):	2 hours

配件 ACCESSORIES:

电池(Battery):	2块(pcs)
充电器(Charger):	1个(pc)
密封件(Sealing element):	1套(set)



产品特点:

- 强劲大容量 18V 锂电池驱动, 用途广泛
- 高强度特殊切刀片, 坚固耐用
- 螺帽破切完成后自动复位, 效率高
- 握把符合人体工程学, 操作舒适

FEATURES:

- Powerful and high-capacity 18V lithium battery drive, versatile
- High-strength special cutting blade, strong and durable
- The nut is automatically reset after the cutting is completed, high efficiency
- Ergonomic grip and comfortable operation

EC-2432A 充电式螺帽破切器 Battery powered nut breaker

技术参数 TECHNICAL DATA:

出力(Crimping force):	120KN
六角螺帽范围(Hex nut range):	M10-M24
行程(Stroke):	32mm
电池电压(Voltage):	18V
电池容量(Capacity):	5.0Ah
充电时间(Charging time):	2 hours

配件 ACCESSORIES:

电池(Battery):	2块(pcs)
充电器(Charger):	1个(pc)
密封件(Sealing element):	1套(set)



产品特点:

- 电池余电及电压油压显示更直观
- 强劲大容量 18V 锂电池驱动, 用途广泛
- 握把符合人体工程学, 操作舒适
- 设有加油口, 易于维护

FEATURES:

- More intuitive display of battery power and voltage and oil pressure
- Powerful and high-capacity 18V lithium battery drive, versatile
- Ergonomic grip and comfortable operation
- With fuel filler, easy to maintain

EZ-18 充电式钢筋剪 Battery rebar cutter

技术参数 TECHNICAL DATA:

出力(Crimping force):	120KN
行程(Stroke):	18mm
剪切范围(Crimping range):	Φ4-18mm
电池电压(Voltage):	18V
电池容量(Capacity):	5.0Ah
充电时间(Charging time):	2 hours

配件 ACCESSORIES:

电池(Battery):	2块(pcs)
充电器(Charger):	1个(pc)
密封件(Sealing element):	1套(set)



安全/ 高效/ 可靠/ 轻便/
SAFETY/ HIGH EFFICIENCY/ TRUSTFUL/ EASIER/



整体式液压钳 HYDRAULIC CRIMPING TOOLS

产品特点:

- 特选高碳钢材质一体原材料CNC电脑加工, 抗张性强, 压接精度高
- 10KV-500KV高压绝缘套管、线夹、裸端子、六角形压着, 紧密不脱落

FEATURES:

- Specially selected high-carbon steel material integrated with CNC computer processing, strong tensile strength, high crimping accuracy
- 10KV-500KV high voltage extension cable bushing, wire clamp, bare terminal, hexagonal crimping, tight and not falling off

KYQ-300C 整体式液压钳 Hydraulic crimping tools

技术参数 TECHNICAL DATA:

出力(Crimping force):	18T
压接范围(Crimping force):	18-300mm ²
压接形式(Crimping type):	六角圆压
行程(Stroke):	22mm
长度(Length):	-
重量(Weight):	5.4Kg
包装(Package):	塑料箱

配件 ACCESSORIES:

模具(Crimping die): 18,25,35,50,70,85,120,150,185,240,300mm²

YQK-240 整体式液压钳 Hydraulic crimping tools

技术参数 TECHNICAL DATA:

出力(Crimping force):	12T
压接范围(Crimping force):	16-240mm ²
压接形式(Crimping type):	六角圆压
行程(Stroke):	20mm
长度(Length):	470mm
重量(Weight):	6.2Kg
包装(Package):	塑料箱

配件 ACCESSORIES:

模具(Crimping die): 16,25,35,50,70,95,120,150,185,240mm²

YQK-300 整体式液压钳 Hydraulic crimping tools

技术参数 TECHNICAL DATA:

出力(Crimping force):	12T
压接范围(Crimping force):	18-300mm ²
压接形式(Crimping type):	六角圆压
行程(Stroke):	20mm
长度(Length):	470mm
重量(Weight):	8.3Kg
包装(Package):	塑料箱

配件 ACCESSORIES:

模具(Crimping die): 18,25,35,50,70,95,120,150,185,240,300mm²

YQK-70 整体式液压钳 Hydraulic crimping tools

技术参数 TECHNICAL DATA:

出力(Crimping force):	8T
压接范围(Crimping force):	4-70mm ²
压接形式(Crimping type):	六角圆压
行程(Stroke):	10mm
长度(Length):	310mm
重量(Weight):	3.0Kg
包装(Package):	塑料箱

配件 ACCESSORIES:

模具(Crimping die): 4,6,10,16,25,35,50,70mm²

YQK-120 整体式液压钳 Hydraulic crimping tools

技术参数 TECHNICAL DATA:

出力(Crimping force):	8T
压接范围(Crimping force):	10-120mm ²
压接形式(Crimping type):	六角圆压
行程(Stroke):	16mm
长度(Length):	400mm
重量(Weight):	4.5Kg
包装(Package):	塑料箱

配件 ACCESSORIES:

模具(Crimping die): 10,16,25,35,50,70,85,120mm²

整体式液压钳

HYDRAULIC CRIMPING TOOLS



整体式液压钳

HYDRAULIC CRIMPING TOOLS

卓越品质 精心所制

卓越品质 精心所制



YQK-70 整体式液压钳

Hydraulic crimping tools

技术参数 TECHNICAL DATA:	
出力(Crimping force):	8T
压接范围(Crimping force):	4-70mm ²
压接形式(Crimping type):	六角圆压
行程(Stroke):	10mm
长度(Length):	310mm
重量(Weight):	3.0Kg
包装(Package):	塑料箱
配件ACCESSORIES:	
模具(Crimping dies):	4,6,10,16,25,35,50,70mm ²

YQK-120 整体式液压钳

Hydraulic crimping tools

技术参数 TECHNICAL DATA:	
出力(Crimping force):	8T
压接范围(Crimping force):	10-120mm ²
压接形式(Crimping type):	六角圆压
行程(Stroke):	16mm
长度(Length):	400mm
重量(Weight):	4.5Kg
包装(Package):	塑料箱
配件ACCESSORIES:	
模具(Crimping dies):	10,16,25,35,50,70,96,120mm ²

YQK-120 整体式液压钳(铝合金)

Hydraulic crimping tools(Aluminum alloy)

技术参数 TECHNICAL DATA:	
出力(Crimping force):	8T
压接范围(Crimping force):	10-120mm ²
压接形式(Crimping type):	六角圆压
行程(Stroke):	14mm
长度(Length):	395mm
重量(Weight):	1.8Kg
包装(Package):	塑料箱
配件ACCESSORIES:	
模具(Crimping dies):	10,16,25,35,50,70,96,120mm ²

YQK-240 整体式液压钳(铝合金)

Hydraulic crimping tools(Aluminum alloy)

技术参数 TECHNICAL DATA:	
出力(Crimping force):	12T
压接范围(Crimping force):	16-240mm ²
压接形式(Crimping type):	六角圆压
行程(Stroke):	18mm
长度(Length):	465mm
重量(Weight):	2.3Kg
包装(Package):	塑料箱
配件ACCESSORIES:	
模具(Crimping dies):	16,25,35,50,70,96,120,150,185,240mm ²



YQK-240 整体式液压钳

Hydraulic crimping tools

技术参数 TECHNICAL DATA:	
出力(Crimping force):	12T
压接范围(Crimping force):	16-240mm ²
压接形式(Crimping type):	六角圆压
行程(Stroke):	20mm
长度(Length):	470mm
重量(Weight):	6.2Kg
包装(Package):	塑料箱
配件ACCESSORIES:	
模具(Crimping dies):	16,25,35,50,70,95,120,150,185,240mm ²

YQK-300 整体式液压钳

Hydraulic crimping tools

技术参数 TECHNICAL DATA:	
出力(Crimping force):	12T
压接范围(Crimping force):	16-300mm ²
压接形式(Crimping type):	六角圆压
行程(Stroke):	20mm
长度(Length):	470mm
重量(Weight):	6.3Kg
包装(Package):	塑料箱
配件ACCESSORIES:	
模具(Crimping dies):	16,25,35,50,70,95,120,150,185,240,300mm ²

YQK-300 整体式液压钳(铝合金)

Hydraulic crimping tools(Aluminum alloy)

技术参数 TECHNICAL DATA:	
出力(Crimping force):	12T
压接范围(Crimping force):	16-300mm ²
压接形式(Crimping type):	六角圆压
行程(Stroke):	18mm
长度(Length):	465mm
重量(Weight):	2.4Kg
包装(Package):	塑料箱
配件ACCESSORIES:	
模具(Crimping dies):	16,25,35,50,70,95,120,150,185,240,300mm ²

HP-70 整体式液压钳

Hydraulic crimping tools

技术参数 TECHNICAL DATA:	
出力(Crimping force):	5T
压接范围(Crimping force):	4-70mm ²
压接形式(Crimping type):	六角圆压
行程(Stroke):	12mm
长度(Length):	300mm
重量(Weight):	1.6Kg
包装(Package):	塑料箱
配件ACCESSORIES:	
模具(Crimping dies):	4,6,10,16,25,35,50,70mm ²

整体式液压钳

HYDRAULIC CRIMPING TOOLS



整体式液压钳

HYDRAULIC CRIMPING TOOLS

产品特点:

- 适用于铝塑、PEX管、PB管等与铜管件、铜接头连接
- 卡压不锈钢套(防漏气)、铜套、铝套
- 压接头部可自由旋转360°,可在狭窄地方工作
- 液压系统稳定,轻巧容易携带
- 双速进油设计,压接速度快

FEATURES:

- It is applicable to the connection of aluminum plastic, PEX pipe, PB pipe, etc.
- with copper pipe fittings and copper joints
- Crimping stainless steel sleeve (air leakage proof), copper sleeve and aluminum sleeve
- The crimping head can rotate 360° freely and work in a narrow place
- Stable hydraulic system, light and easy to carry
- Double speed oil inlet design, quick crimping



GC-1525/CW-1632 整体式压管工具

Integral pipe pressing tool

技术参数 TECHNICAL DATA:	
出力(Output):	10T
行程(Stroke):	22mm
长度(Length):	480mm
重量(Weight):	3.15Kg(不含包装)
配件 ACCESSORIES:	
模具(Crimping die):	
不锈钢压接(Stainless steel crimping):	Φ16, Φ20, Φ25, Φ32mm
铝塑管压接(Aluminum plastic pipe crimping):	
A模具(Mould):	Φ16, Φ20, Φ(25)25, Φ32mm
B模具(Mould):	Φ16, Φ20, Φ25, Φ32mm



JT-45/48/50/54/57/60

声测管压管钳 Acoustic tube pressure pipe clamp

技术参数 TECHNICAL DATA:	
出力(Output):	12T
压接范围(Crimping range):	45-60mm
可压壁厚(Crimping wall thickness):	≤2mm
重量(Weight):	5.3Kg
配件 ACCESSORIES:	
模具(Crimping die):	45/48/50/54/57/60



FS-7842 整体式空调管压接钳

Integral air conditioning pipe crimping pliers

技术参数 TECHNICAL DATA:	
出力(Output):	8T
行程(stroke):	15mm
压接范围(Crimping range):	3/8-7/8(3分-7分)
压接形式(Crimping form):	点式六角圆压
液压油(Hydraulic oil):	7-32号机械油
产品尺寸(Product Size):	380×45×62mm
重量(Weight):	6.9Kg
包装(Package):	塑料箱(Plastic box)
配件 ACCESSORIES:	
模具(Crimping die):	6SRB, 6-6SRB, 8, 10SRB, 10, 12SRB, 12



产品特点:

- 二段高速、低压,进油迅速,操作容易回油方便
- 采用旋转式挤压方式迅速回油
- 当压力到达700kg/cm²(12T)时所设计安全保护装置
- 压接头部可以180度旋转
- 玻璃纤维操作绝缘棒,可耐电压20Kv,持续5分钟

FEATURES:

- High speed, low pressure, fast oil inlet, easy operation and oil return
- Quick oil return by rotary extrusion
- Safety protection device designed when the pressure reaches 700kg/cm²(12T)
- Crimp head can rotate 180°
- Fiberglass operated insulating rod, withstand voltage 20Kv, lasting for 5 minutes

EP-410 整体式液压钳

Hydraulic crimping tools

技术参数 TECHNICAL DATA:	
出力(Crimping force):	12T
压接范围(Crimping force):	16-300mm ²
压接形式(Crimping type):	六角圆压
行程(Stroke):	30mm
尺寸(Size):	613×160×120mm
储油量(Oil storage capacity):	145CC
重量(Weight):	6.8Kg
包装(Package):	塑料箱
配件 ACCESSORIES:	
模具(Crimping dies):	16, 25, 35, 50, 70, 95, 120, 150, 185, 240, 300mm ²



内置安全阀
With safety valve built-in

EP-430 整体式液压钳

Hydraulic crimping tools

技术参数 TECHNICAL DATA:	
出力(Crimping force):	12T
压接范围(Crimping force):	50-400mm ²
压接形式(Crimping type):	六角圆压
行程(Stroke):	32mm
尺寸(Size):	620×165×102mm
储油量(Oil storage capacity):	145CC
重量(Weight):	6.96Kg
包装(Package):	塑料箱
配件 ACCESSORIES:	
模具(Crimping dies):	50, 70, 95, 120, 150, 185, 240, 300, 400mm ²



内置安全阀
With safety valve built-in

EP-510 整体式液压钳

Hydraulic crimping tools

技术参数 TECHNICAL DATA:	
出力(Crimping force):	13T
压接范围(Crimping force):	50-400mm ²
压接形式(Crimping type):	六角圆压
行程(Stroke):	38mm
尺寸(Size):	635×170×105mm
储油量(Oil storage capacity):	145CC
重量(Weight):	6.96Kg
包装(Package):	塑料箱
配件 ACCESSORIES:	
模具(Crimping die):	50, 70, 95, 120, 150, 185, 240, 300, 400mm ²



内置安全阀
With safety valve built-in

整体式液压钳

HYDRAULIC CRIMPING TOOLS



安全/ 高效/ 可靠/ 轻便/

SAFETY/ HIGH EFFICIENCY/ TRUSTFUL/ EASIER/

分体式液压钳

HYDRAULIC CRIMPING TOOLS

卓越品质 精心所制



内置安全阀
With safety valve built-in

HT-300 整体式液压钳(铝合金) Hydraulic crimping tools(Aluminum alloy)

技术参数 TECHNICAL DATA:	
出力(Crimping force):	80KN
压接范围(Crimping force):	18-300mm ²
压接形式(Crimping type):	六角圆压
行程(Stroke):	17mm
长度(Length):	460mm
重量(Weight):	3.3Kg
包装(Package):	铁箱
配件ACCESSORIES:	
模具(Crimping die):	18,25,35,50,70,95,120,150,185,240,300mm ²



内置安全阀
With safety valve built-in

HT-400 整体式液压钳(铝合金) Hydraulic crimping tools(Aluminum alloy)

技术参数 TECHNICAL DATA:	
出力(Crimping force):	120KN
压接范围(Crimping force):	18-400mm ²
压接形式(Crimping type):	六角圆压
行程(Stroke):	42mm
长度(Length):	595mm
重量(Weight):	6.7Kg
包装(Package):	铁箱
配件ACCESSORIES:	
模具(Crimping die):	18,25,35,50,70,95,120,150,185,240,300,400mm ²



YQK-400C 整体式液压钳 Hydraulic crimping tools

技术参数 TECHNICAL DATA:	
出力(Crimping force):	20T
压接范围(Crimping force):	16-400mm ²
压接形式(Crimping type):	六角圆压
行程(Stroke):	22mm
长度(Length):	—
重量(Weight):	5-7Kg
包装(Package):	塑料箱
配件ACCESSORIES:	
模具(Crimping die):	18,25,35,50,70,95,120,150,185,240,300,400mm ²



内置安全阀
With safety valve built-in

HT-51 整体式液压钳 Hydraulic crimping tools

技术参数 TECHNICAL DATA:	
出力(Crimping force):	60KN
压接范围(Crimping force):	10-240mm ²
压接形式(Crimping type):	六角圆压
行程(Stroke):	16mm
长度(Length):	380mm
重量(Weight):	3Kg
包装(Package):	铁箱
配件ACCESSORIES:	
模具(Crimping die):	10,16,25,35,50,70,95,120,150,185,240mm ²



产品特点:

- 适用于输配电室内屋外工程,各种接线金具、架空地下电缆线专业使用
- 高压电缆套管、线夹、裸端子、六角型压着,紧密不易脱落,导电良好
- 模具规格不合适,欢迎订制
- 油管接头配PT3/8"牙

FEATURES:

- It is suitable for indoor and outdoor works of power transmission and distribution room, professional use of various connecting hardware and overhead underground cable
- High voltage cable sleeve, clamp, bare terminal, hexagonal pressing, tight and not easy to fall off, good conductivity
- If the mold specification is not right, you are welcome to order
- Oil pipe joint with pT3/8"thread

ZCO-300B 分体式液压钳 Hydraulic crimping tools

技术参数 TECHNICAL DATA:	
出力(Crimping force):	10T
压接范围(Crimping force):	16-300mm ²
压接形式(Crimping type):	六角圆压
行程(Stroke):	17mm
重量(Weight):	3.5Kg
包装(Package):	铁箱
配件ACCESSORIES:	
模具(Crimping die):	16,25,35,50,70,95,120,150,185,240,300mm ²

分体式液压钳

HYDRAULIC CRIMPING TOOLS



分体式液压钳

HYDRAULIC CRIMPING TOOLS

产品特点:

- 适用于输配电室内屋外工程, 各种接续金具、架空地下电缆线专业使用
- 高压电缆套管、线夹、裸端子、六角型压着, 紧密不易脱落, 导电良好
- 模具规格不合适, 欢迎订制
- 油管接头配PT3/8"牙

FEATURES:

- It is suitable for indoor and outdoor works of power transmission and distribution room, professional use of various connecting hardware and overhead underground cable
- High voltage cable sleeve, clamp, bare terminal, hexagonal pressing, tight and not easy to fall off, good conductivity
- If the mold specification is not right, you are welcome to order
- Oil pipe joint with pT3/8" thread



EP-410 分体式液压钳

Hydraulic crimping tools

技术参数 TECHNICAL DATA:	
出力(Crimping force):	11T
压接范围(Crimping force):	35-300mm ²
压接形式(Crimping type):	六角圆压
行程(Stroke):	32mm
重量(Weight):	8Kg
包装(Package):	铁箱
配件ACCESSORIES:	
模具(Crimping die):	35,50,70,95,120,150,185,240,300mm ²

CYO-400B 分体式液压钳

Hydraulic crimping tools

技术参数 TECHNICAL DATA:	
出力(Crimping force):	12T
压接范围(Crimping force):	50-400mm ²
压接形式(Crimping type):	六角圆压
行程(Stroke):	32mm
重量(Weight):	8Kg
包装(Package):	铁箱
配件ACCESSORIES:	
模具(Crimping die):	50,70,95,120,150,185,240,300,400mm ²

FYQ-240/300 分体式液压钳

Hydraulic crimping tools

技术参数 TECHNICAL DATA:	
出力(Crimping force):	16T
压接范围(Crimping force):	16-240mm ² /16-300mm ²
压接形式(Crimping type):	六角圆压
行程(Stroke):	20mm
重量(Weight):	2.65Kg
包装(Package):	硬纸箱
配件ACCESSORIES:	
模具(Crimping die):	16,25,35,50,70,95,120,150,185,240(300)mm ²

FYQ-400/500 分体式液压钳

Hydraulic crimping tools

技术参数 TECHNICAL DATA:	
出力(Crimping force):	20T
压接范围(Crimping force):	16-400mm ² /16-500mm ²
压接形式(Crimping type):	六角圆压
行程(Stroke):	20mm
重量(Weight):	5.6Kg
包装(Package):	硬纸箱
配件ACCESSORIES:	
模具(Crimping die):	16,25,35,50,70,95,120,150,185,240,300,400(500)mm ²

全新升级 钳头包胶处理



EP-510H 分体式液压钳

Hydraulic crimping tools

技术参数 TECHNICAL DATA:	
出力(Crimping force):	13T
压接范围(Crimping force):	50-400mm ²
压接形式(Crimping type):	六角圆压
行程(Stroke):	38mm
重量(Weight):	8.5Kg
包装(Package):	铁箱
配件ACCESSORIES:	
模具(Crimping die):	50,70,95,120,150,185,240,300,400mm ²

EP-610H 分体式液压钳

Hydraulic crimping tools

技术参数 TECHNICAL DATA:	
出力(Crimping force):	13T
压接范围(Crimping force):	50-400mm ²
压接形式(Crimping type):	六角圆压
行程(Stroke):	42mm
重量(Weight):	8.5Kg
包装(Package):	塑料箱
配件ACCESSORIES:	
模具(Crimping die):	50,70,95,120,150,185,240,300,400mm ²



FYQ-630 分体式液压钳

Hydraulic crimping tools

技术参数 TECHNICAL DATA:	
出力(Crimping force):	35T
压接范围(Crimping force):	150-630mm ²
压接形式(Crimping type):	六角圆压
行程(Stroke):	25mm
重量(Weight):	17.5Kg
包装(Package):	木箱
配件ACCESSORIES:	
模具(Crimping die):	150,185,240,300,400,500,630mm ²

FYQ-1000 分体式液压钳

Hydraulic crimping tools

技术参数 TECHNICAL DATA:	
出力(Crimping force):	55T
压接范围(Crimping force):	400-1000mm ²
压接形式(Crimping type):	六角圆压
行程(Stroke):	24mm
重量(Weight):	23.7Kg
包装(Package):	木箱
配件ACCESSORIES:	
模具(Crimping die):	400,500,630,800,1000mm ²

分体式液压钳 HYDRAULIC CRIMPING TOOLS



分体式液压钳 HYDRAULIC CRIMPING TOOLS

产品特点:

- 重量轻, 便于携带
- 压接范围宽, 可通过转换模使用12吨压模
- 可更换的宽压模设计, 压接次数少, 操作简单

FEATURES:

- The tool features with H type head interchangeable dies.
- For ease of operation and comfort the operator can make the tool head fully rotated tool 350° a double speed action reflected by a fast advancing speed for rapid approach of the crimping die the connector and a slower more powerful speed for crimping
- The built-in safety valve will by-pass the oil supply when the maximum pressure is reached, automatically pressure release.
- Manual retract after crimping



CO-25 分体式液压钳 Hydraulic crimping tools

技术参数 TECHNICAL DATA:	
出力(Crimping force):	26T
压接范围(Crimping range):	16-630mm ²
压接形式(Crimping type):	六角圆压
额定压力(Rated pressure):	70Mpa(700bar)
重量(Weight):	5.3Kg (不含模具)
包装(Package):	铁箱
配件ACCESSORIES:	
模具(Crimping dies):	150,165,240,300,400,500,630mm ²

产品特点:

- 重量轻, 便于携带
- 压接范围宽, 可通过转换模使用12吨压模
- 可更换的宽压模设计, 压接次数少, 操作简单

FEATURES:

- The tool features with H type head interchangeable dies.
- For ease of operation and comfort the operator can make the tool head fully rotated tool 350° a double speed action reflected by a fast advancing speed for rapid approach of the crimping die the connector and a slower more powerful speed for crimping
- The built-in safety valve will by-pass the oil supply when the maximum pressure is reached, automatically pressure release.
- Manual retract after crimping



CO-45 分体式液压钳 Hydraulic crimping tools

技术参数 TECHNICAL DATA:	
出力(Crimping force):	45T
压接范围(Crimping range):	120-1000mm ²
压接形式(Crimping type):	六角圆压
额定压力(Rated pressure):	70Mpa(700bar)
重量(Weight):	11Kg (不含模具)
包装(Package):	铁箱
配件ACCESSORIES:	
模具(Crimping dies):	400,500,630,800,1000mm ²

产品特点:

- 适用于100KV以上架空耐张套管压接, 以及地下电缆之接续作业
- 复动式液压油缸可免除弹簧性疲乏复位慢的问题
- 可移动式模具可以协助操作人员压接之后容易取出模具

FEATURES:

- Suitable for crimping of overhead tensile casings above 100KV and connection of underground cables
- The double-acting hydraulic cylinder can avoid the problem of slow return from spring fatigue
- Movable mold can assist the operator to easily take out the mold after crimping



CO-60S 大吨位压接机 Large tonnage press

技术参数 TECHNICAL DATA:	
压力(Crimping force):	60T
行程(Stroke):	22mm
压接范围(Crimping range):	铜铝端子套管Φ60mm 铜套管Φ26mm
压接形式(Crimping type):	六角式(Hexagon crimping)
包装尺寸(Package Size):	250×215×355mm
重量(Weight):	22.0kg
包装(Package):	木箱(Wooden case)



CO-100S 大吨位压接机 Large tonnage press

技术参数 TECHNICAL DATA:	
压力(Crimping force):	100T
行程(Stroke):	24mm
压接范围(Crimping range):	铜套管Φ64mm 铝套管Φ71mm 铜套管Φ32mm
压接形式(Crimping type):	六角式(Hexagon crimping)
包装尺寸(Package Size):	250×215×355mm
重量(Weight):	22.0kg
包装(Package):	木箱(Wooden case)



CO-200S 大吨位压接机 Large tonnage press

技术参数 TECHNICAL DATA:	
压力(Crimping force):	200T
行程(Stroke):	35mm
压接范围(Crimping range):	铜套管Φ86mm 铝套管Φ90mm 铜套管Φ50mm
压接形式(Crimping type):	六角式(Hexagon crimping)
包装尺寸(Package Size):	475×310×250mm
重量(Weight):	98.0kg
包装(Package):	木箱(Wooden case)



分体式液压钳 HYDRAULIC CRIMPING TOOLS



分体式液压钳 HYDRAULIC CRIMPING TOOLS

产品特点:

- 适用于铝塑、PEX管、PB管等与钢管件，铜接头连接
- 卡压不锈钢套(防漏气)、铜套、铝套
- 压接头部可自由旋转360°，可在较窄地方工作
- 配置3/8快速接头和防尘帽

FEATURES:

- It is applicable to the connection of aluminum plastic, PEX pipe, PB pipe, etc.
- with copper pipe fittings and copper joints
- Clamping stainless steel sleeves (air leakage proof), copper sleeve and aluminum sleeve
- The crimping head can rotate 360° freely and work in a narrow place
- Equipped with 3/8 quick coupling and dust cap



GC-1525/GC-1632 分体式压管工具 Split pipe pressing tool

技术参数 TECHNICAL DATA:	
出力(Output):	16T
长度(Length):	280mm
重量(Weight):	2.9Kg
配件 ACCESSORIES:	
模具(Crimping dies):	
不锈钢压接(Stainless steel crimping):	Φ16, Φ20, Φ26, Φ32mm
铝塑管压接(Aluminum plastic pipe crimping):	
A模具(Mould):	Φ16, Φ20, Φ(26)26, Φ32mm
B模具(Mould):	Φ16, Φ20, Φ25, Φ32mm



DN-1550 分体式压管工具 Split pipe pressing tool

技术参数 TECHNICAL DATA:	
出力(Output):	6.6T
行程(Stroke):	35mm
压接范围(Crimp range):	DN15-DN50不锈钢管件
压接形式(Crimp type):	圆形
配件 ACCESSORIES:	
模具(Crimping dies):	DN15, DN20, DN25, DN32, DN40, DN50

DN15, DN20, DN25, DN32, DN40, DN50模具对应管径参数表 Diameter parameter table of DN15, DN20, DN25, DN32, DN40, DN50 mould

公称管径 (Pipe diameter nominal)	I 系列管子 (I series pipe)	II 系列管子 (II series pipe)	管壁厚度 (Pipe wall thickness)
DN15	16mm	16mm	0.8mm
DN20	20mm	22.2mm	1mm
DN25	25.4mm	28.8mm	1mm
DN32	32mm	34mm	1.2mm
DN40	40mm	42.7mm	1.2mm
DN50	50.8mm	48.8mm	1.2mm

右边模具是针对国标 GB/T 19228 不锈钢管件的可靠压接。
The right moulds is for reliable crimping of national standard GB/T 19228 stainless steel pipe fittings.



DN1525/3250 分体式压管工具 Split pipe pressing tool

技术参数 TECHNICAL DATA:	
出力(Output):	6.5T
行程(Stroke):	35mm
压接范围(Crimp range):	DN15-DN50不锈钢管件
压接形式(Crimp type):	圆形
配件 ACCESSORIES:	
模具(Crimping dies):	DN15, DN20, DN25, DN32, DN40, DN50



DN15, DN20, DN25, DN32, DN40, DN50模具对应管径参数表 Diameter parameter table of DN15, DN20, DN25, DN32, DN40, DN50 mould

公称管径 (Pipe diameter nominal)	I 系列管子 (I series pipe)	II 系列管子 (II series pipe)	管壁厚度 (Pipe wall thickness)
DN15	16mm	16mm	0.8mm
DN20	20mm	22.2mm	1mm
DN25	25.4mm	28.8mm	1mm
DN32	32mm	34mm	1.2mm
DN40	40mm	42.7mm	1.2mm
DN50	50.8mm	48.8mm	1.2mm

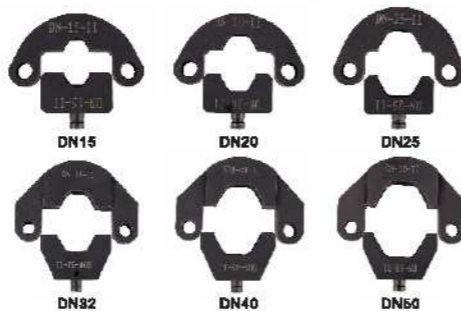

右边模具是针对国标 GB/T 19228 不锈钢管件的可靠压接。
The right moulds is for reliable crimping of national standard GB/T 19228 stainless steel pipe fittings.

DN-65100 分体式压管工具 Split pipe pressing tool

技术参数 TECHNICAL DATA:	
出力(Output):	6.5T
行程(Stroke):	95mm
压接范围(Crimp range):	DN60-DN100不锈钢管件(Stainless steel pipe)
压接形式(Crimp type):	环形(Annular)
配件 ACCESSORIES:	
模具(Crimping dies):	DN65, DN80, DN100mm

DN65, DN80, DN100模具对应管径参数表 Diameter parameter table of DN65, DN80, DN100 mould

公称管径 (Pipe diameter nominal)	I 系列管子 (I series pipe)	II 系列管子 (II series pipe)	管壁厚度 (Pipe wall thickness)
DN65	76.1mm	76.1mm	1.8mm
DN80	88.9mm	88.9mm	1.8mm
DN100	101.6mm	108mm	1.8mm



安全/ 高效/ 可靠/ 轻便/
SAFETY/ HIGH EFFICIENCY/ TRUSTFUL/ EASIER/



产品特点:

- 结构紧凑,使用灵活,重量轻,体积小,携带方便
- 利用新型油压拔轮工具,操作轻而易举
- 可以自由旋转,依拔轮距离离活塞中心点,很快可碰到被拔的中心点

FEATURES:

- Compact structure, flexible use, light weight, small size, easy to carry
- It is easy to operate by using the new type of oil pressure puller
- It can rotate freely. According to the distance between the puller and the piston center point.
- It can touch the center point to be pulled quickly



可横拉
(Can be pulled horizontally)



YL-SERIES 整体式液压拉马
Hydraulic puller

技术参数 TECHNICAL DATA:

型号 (Model)	吨位出力 (Output)	横向最大拉距 (Max. horizontal draw distance)	纵向最大拉距 (Max. longitudinal draw distance)	轴心行程 (Axle stroke)	螺纹直径 (Thread diameter)	重量 (Weight)
YL-5T	5T	200mm	140mm	50mm	45mm	5.8Kg
YL-10T	10T	250mm	180mm	50mm	60mm	9Kg
YL-15T	15T	300mm	180mm	50mm	80mm	10Kg
YL-20T	20T	350mm	200mm	60mm	72mm	15Kg
YL-30T	30T	400mm	250mm	60mm	88mm	23Kg
YL-50T	50T	500mm	400mm	60mm	108mm	36Kg

产品特点:

- 结构紧凑,使用灵活,重量轻,体积小,携带方便
- 利用新型油压拔轮工具,操作轻而易举
- 可以自由旋转,依拔轮距离离活塞中心点,很快可碰到被拔的中心点
- 30T以上的油缸必须配大油量的油泵
- 油管接头配ZG3/8"牙

FEATURES:

- Compact structure, flexible use, light weight, small size, easy to carry
- It is easy to operate by using the new type of oil pressure puller
- It can rotate freely. According to the distance between the puller and the piston center point.
- It can touch the center point to be pulled quickly



EP-SERIES 分体式液压拉马
Hydraulic puller

技术参数 TECHNICAL DATA:

型号 (Model)	吨位出力 (Output)	横向最大拉距 (Max. horizontal draw distance)	纵向最大拉距 (Max. longitudinal draw distance)	轴心行程 (Axle stroke)	爪数 (Claw number)	重量 (Weight)
EP-5T	5T	200mm	140mm	60mm	2-3	6Kg
EP-10T	10T	250mm	160mm	60mm	2-3	9.5Kg
EP-15T	15T	300mm	180mm	60mm	2-3	10Kg
EP-20T	20T	350mm	200mm	60mm	2-3	14.5Kg
EP-30T	30T	400mm	250mm	60mm	2-3	22Kg
EP-50T	50T	500mm	400mm	60mm	2-3	34Kg
EP-100T	100T	600mm	300mm	60mm	2-3	50Kg

YL-SERIES 整体式液压拉马(铝合金)
Hydraulic puller

技术参数 TECHNICAL DATA:

型号 (Model)	吨位出力 (Output)	横向最大拉距 (Max. horizontal draw distance)	纵向最大拉距 (Max. longitudinal draw distance)	轴心行程 (Axle stroke)	螺纹直径 (Thread diameter)	重量 (Weight)
YL-5T	5T	200mm	140mm	50mm	45mm	8Kg
YL-10T	10T	250mm	180mm	50mm	60mm	10Kg
YL-15T	15T	300mm	180mm	50mm	80mm	11Kg
YL-20T	20T	350mm	200mm	60mm	73mm	16Kg
YL-30T	30T	400mm	250mm	60mm	88mm	24Kg
YL-50T	50T	500mm	400mm	60mm	110mm	38Kg

安全/ 高效/ 可靠/ 轻便/
SAFETY/ HIGH EFFICIENCY/ TRUSTFUL/ EASIER/

电动液压钢筋弯曲机
HYDRAULIC STEEL BENDING MACHINE



RC-20/22/25



NRB-25 电动钢筋弯曲机(无刷电机)
Electric steel bending machine (brushless motor)

技术参数 TECHNICAL DATA:

电机类型(Motor type):	无刷电机 (brushless motor)
电压(Voltage):	110/220V
功率(power):	1500W
弯曲速度(Bending speed):	约6秒
弯曲角度(Bending angle):	0-130度
弯曲范围(Bending range):	6-25mm
重量(Weight):	18/16Kg
机器尺寸(Machine size):	560×170×220mm



NRB-35 电动钢筋弯曲机(无刷电机)
Electric steel bending machine (brushless motor)

技术参数 TECHNICAL DATA:

电机类型(Motor type):	无刷电机 (brushless motor)
电压(Voltage):	110/220V
功率(power):	1350W
弯曲速度(Bending speed):	约6秒
弯曲角度(Bending angle):	0-130度
弯曲范围(Bending range):	6-32mm
重量(Weight):	32/24Kg
机器尺寸(Machine size):	560×260×200mm

产品特点:

- 高强度弯曲模具
- 220V/110V交流电液压驱动, 弯曲钢筋迅速, 时间短
- 长螺栓来限制行程, 实现精准弯曲
- 弯曲完成或半途出错时, 可通过手动复位键将活塞退回超始位置
- 专用于弯曲钢筋及各种钢棒

FEATURES:

- High-strength bending die
- 220V/110V AC hydraulic drive, bending steel bar quickly and short time
- Long bolts to limit the stroke and achieve precise bending
- When the bending is completed or there is an error in the middle, the piston can be returned to the over-start position by the manual reset button
- Dedicated to bending steel bars and various steel bars



RC-16



RC-32

RC-SERIES 电动液压钢筋剪
Electric hydraulic steel cutter

技术参数 TECHNICAL DATA:

型号 (Model)	电压 (Voltage)	切断直径 (Cutting range)	切断速度 (Cutting speed)	空载功率 (No-load power)	包装尺寸 (Package dimensions)	机器重量 (Weight)
RC-16	220/110V	Φ4-16mm	2.5-3S	850/900W	510×230×150mm	13Kg/8Kg
RC-20	220/110V	Φ4-20mm	3-3.5S	950/1350W	480×195×280mm	18.3Kg/13Kg
RC-22	220/110V	Φ4-22mm	3.5-4.5S	1000/1350W	480×195×280mm	21.5Kg/15Kg
RC-25	220/110V	Φ4-25mm	5S	1600/1700W	560×230×345mm	32Kg/24.5Kg
RC-32	220/110V	Φ4-32mm	8-7S	2800/3000W	830×240×350mm	40Kg/31Kg

RB-SERIES 电动钢筋弯曲机(有刷电机)
Electric steel bending machine (Brushed motor)

技术参数 TECHNICAL DATA:

型号 (Model)	电机类型 (Motor type)	电压 (Voltage)	功率 (Power)	弯曲速度 (Bending speed)	弯曲角度 (Bending angle)	弯曲范围 (Bending range)	重量 (Weight)	机器尺寸 (Machine size)
RB-16	有刷电机	220/110V	800/900W	约5秒	0-130度	4-16mm	16.5Kg/15Kg	600×170×200mm
RB-20	有刷电机	220/110V	1100/1500W	约5秒	0-130度	4-22mm	24.5Kg/17Kg	620×170×210mm

液压钢筋剪 HYDRAULIC REBAR CUTTER



液压钢筋剪 HYDRAULIC REBAR CUTTER

产品特点:

- 开口式刀头设计, 使用方便, 可快速更换刀片
- 高强度特殊钢剪切刀片, 坚固耐用
- 钢制外壳和手柄, 坚固耐用
- 切割完成后, 旋转泄压阀即可完成复位

FEATURES:

- Open cutter head design, easy to use, quick blade change
- High-strength special steel shear blade, strong and durable
- Steel shell and handle, sturdy and durable
- After the cutting is completed, the pressure relief valve can be rotated to complete the reset

产品特点:

- 开口式刀头设计, 使用方便, 可快速更换刀片
- 高强度特殊钢剪切刀片, 坚固耐用
- 钢制外壳和手柄, 坚固耐用
- 切割完成后, 旋转泄压阀即可完成复位

FEATURES:

- Open cutter head design, easy to use, quick blade change
- High-strength special steel shear blade, strong and durable
- Steel shell and handle, sturdy and durable
- After the cutting is completed, the pressure relief valve can be rotated to complete the reset



SC-12 整体式液压钢筋剪 Hydraulic rebar cutter

技术参数 TECHNICAL DATA:	
出力(Output):	8T
剪切范围(Cutting range):	Φ4-12mm
长度(Length):	310mm
重量(Weight):	2.8Kg



SC-16 整体式液压钢筋剪 Hydraulic rebar cutter

技术参数 TECHNICAL DATA:	
出力(Output):	8T
剪切范围(Cutting range):	Φ4-18mm
长度(Length):	425mm
重量(Weight):	4.8Kg



SC-22 整体式液压钢筋剪 Hydraulic rebar cutter

技术参数 TECHNICAL DATA:	
出力(Output):	12T
剪切范围(Cutting range):	Φ4-22mm
长度(Length):	495mm
重量(Weight):	8.4Kg



SC-25 整体式液压钢筋剪 Hydraulic rebar cutter

技术参数 TECHNICAL DATA:	
出力(Output):	12T
剪切范围(Cutting range):	Φ4-25mm
长度(Length):	500mm
重量(Weight):	8.8Kg

SC-27 整体式液压钢筋剪 Hydraulic rebar cutter

技术参数 TECHNICAL DATA:	
出力(Output):	12T
剪切范围(Cutting range):	Φ4-27mm
长度(Length):	510mm
重量(Weight):	6.8Kg



YQ-12B 整体式液压钢筋剪 Hydraulic rebar cutter

技术参数 TECHNICAL DATA:	
剪切范围(Cutting range):	Φ4-12mm
尺寸(Size):	560×71×150mm
重量(Weight):	4.08Kg
包装(Package):	塑料箱 plastic box
储油量(Oil storage capacity):	approx.50ml



YQ-16C 整体式液压钢筋剪 Hydraulic rebar cutter

技术参数 TECHNICAL DATA:	
剪切范围(Cutting range):	Φ4-16mm
尺寸(Size):	610×75×200mm
重量(Weight):	5.0Kg
包装(Package):	塑料箱 plastic box
储油量(Oil storage capacity):	approx.50ml



液压钢筋剪

HYDRAULIC REBAR CUTTER



液压钢筋剪

HYDRAULIC REBAR CUTTER

产品特点:

- 高强度特殊钢剪切刀片, 坚固耐用
- 开口式刀头设计, 使用方便, 可快速更换刀片
- 配置3/8接头和防尘帽, 可连接各式压力液压泵

FEATURES:

- High-strength special steel shear blade, strong and durable
- Open cutter head design, easy to use, quick blade change
- Equipped with 3/8 connector and dust cap, can be connected to various pressure hydraulic pumps



产品特点:

- 高强度特殊钢剪切刀片, 坚固耐用
- 开口式刀头设计, 使用方便, 可快速更换刀片
- 360度万向旋转接头, 扩大使用范围
- 配置3/8接头和防尘帽, 可连接各式压力液压泵

FEATURES:

- High-strength special steel shear blade, strong and durable
- Open cutter head design, easy to use, quick blade change
- 360 degree universal rotary joint, expand the scope of use
- Equipped with 3/8 connector and dust cap, can be connected to various pressure hydraulic pumps



SC-12 分体式液压钢筋剪

Hydraulic rebar cutter

技术参数 TECHNICAL DATA:

出力(Output):	8T
剪切范围(Cutting range):	Φ4-12mm
重量(Weight):	2.0Kg



SC-16 分体式液压钢筋剪

Hydraulic rebar cutter

技术参数 TECHNICAL DATA:

出力(Output):	8T
剪切范围(Cutting range):	Φ4-16mm
重量(Weight):	2.1Kg

HPB-22 分体式液压钢筋剪

Hydraulic rebar cutter

技术参数 TECHNICAL DATA:

出力(Output):	30T
剪切对象(Cut object):	普通建筑钢筋/圆钢/螺纹钢
剪切范围(Cutting range):	HPB235(8-22mm), HRB335(8-22mm) HPB400(8-20mm), RRB400(8-20mm)
钢筋分类(Rebar classification):	按力学性能分类
	HPB235级钢筋(一级), HRB335级钢筋(二级) HPB400级钢筋(三级), RRB400级钢筋(四级)
重量(Weight):	6.6Kg



产品特点:

- 高强度特殊钢剪切刀片, 坚固耐用
- 开口式刀头设计, 使用方便, 可快速更换刀片
- 360度万向旋转接头, 扩大使用范围
- 配置3/8接头和防尘帽, 可连接各式压力液压泵

FEATURES:

- High-strength special steel shear blade, strong and durable
- Open cutter head design, easy to use, quick blade change
- 360 degree universal rotary joint, expand the scope of use
- Equipped with 3/8 connector and dust cap, can be connected to various pressure hydraulic pumps



SC-22 分体式液压钢筋剪

Hydraulic rebar cutter

技术参数 TECHNICAL DATA:

出力(Output):	12T
剪切范围(Cutting range):	Φ4-22mm
重量(Weight):	3.5Kg



SC-25 分体式液压钢筋剪

Hydraulic rebar cutter

技术参数 TECHNICAL DATA:

出力(Output):	14T
剪切范围(Cutting range):	Φ4-25mm
重量(Weight):	5.0Kg

HPB-35 分体式液压钢筋剪

Hydraulic rebar cutter

技术参数 TECHNICAL DATA:

出力(Output):	—
剪切对象(Cut object):	普通建筑钢筋/圆钢/螺纹钢
剪切范围(Cutting range):	HPB235(8-35mm), HRB335(8-32mm) HPB400(8-30mm), RRB400(8-28mm)
钢筋分类(Rebar classification):	按力学性能分类
	HPB235级钢筋(一级), HRB335级钢筋(二级) HPB400级钢筋(三级), RRB400级钢筋(四级)
重量(Weight):	16/18.7Kg



液压钢筋弯曲机

HYDRAULIC STEEL BENDING MACHINE



液压钢筋弯曲机

HYDRAULIC STEEL BENDING MACHINE

产品特点:

- 适合钢筋绑扎后或混凝土浇筑后普通弯曲机难以达到之部份等工地现场作业
- 采用超高压液压系统驱动, 弯曲力大
- 机器无需要更换工作头, 可进行钢筋弯曲、拉直工作
- 机器操作简单, 节省劳动力, 便于移动

FEATURES:

- It is suitable for ordinary bending machine after the steel bar is tied or concrete is poured. on-site operations such as the reached part
- Driven by ultra-high pressure hydraulic system, large bending force
- The machine does not need to replace the working head, and can bend and straighten the steel bar
- The machine is easy to operate, save labor, and is easy to move

产品特点:

- 整体结构简单, 操作使用方便。稳定性好, 可靠性高, 保证钢筋折弯的质量, 提高工作效率
- 适合钢筋绑扎后或混凝土浇筑后普通弯曲机难以达到之部份等工地现场作业

FEATURES:

- The overall structure is simple and easy to operate. Good stability, high reliability, guarantee the quality of steel bar bending improves work efficiency
- It is suitable for ordinary bending machine after the steel bar is tied or concrete is poured.
- On-site operations such as the reached part



RB-SERIES 手提式分体钢筋弯曲机

Portable split steel bar bending machine

技术参数 TECHNICAL DATA:

型号 (Model)	适配泵站功率 (Suitable pump station power)	适配电压 (Adaptation voltage)	弯曲范围 (Bending range)	弯曲角度 (Bending angle)	调直角度 (Straighten the angle)	重量 (Weight)
RB-25	0.75Kw/1.5Kw	110V/220V/380V	Φ4-25mm	0-90度	0-90度	15Kg
RB-32	0.75Kw/3.0Kw	220V/380V	Φ4-32mm	0-90度	0-90度	20Kg
RB-40	0.75Kw/3.0Kw	220V/380V	Φ4-40mm	0-90度	0-90度	25Kg

18型 整体式钢筋弯曲机

Integral steel bar bending machine

技术参数 TECHNICAL DATA:

使用范围 (Use range):	可弯曲直径14-18mm钢筋
弯曲角度 (Bending angle):	90度
产品重量 (Weight):	6.5Kg
尺寸 (Size):	长64cm×宽14cm
产品包装 (Package):	木箱



产品特点:

- 整体结构简单, 操作使用方便。稳定性好, 可靠性高, 保证钢筋折弯的质量, 提高工作效率
- 适合钢筋绑扎后或混凝土浇筑后普通弯曲机难以达到之部份等工地现场作业

FEATURES:

- The overall structure is simple and easy to operate. Good stability, high reliability, guarantee the quality of steel bar bending improves work efficiency
- It is suitable for ordinary bending machine after the steel bar is tied or concrete is poured.
- On-site operations such as the reached part

18型 分体式钢筋弯曲机

Integral steel bar bending machine

技术参数 TECHNICAL DATA:

使用范围 (Use range):	可弯曲直径14-18mm钢筋
弯曲角度 (Bending angle):	90度
产品重量 (Weight):	4.5Kg
尺寸 (Size):	长29cm×宽14cm
产品包装 (Package):	纸箱



螺帽破切器 HYDRAULIC NUT CUTTER



螺帽破切器 HYDRAULIC NUT CUTTER

卓越品质 精心所制

卓越品质 精心所制



JK-27 液压螺帽破切器(整体式)
Hydraulic nut cutter

技术参数 TECHNICAL DATA:	
出力(Contribute):	12T
破切范围(Breaking range):	M10-M27
□□□□(Hat to edge):	16-41mm
重量(Weight):	5.0Kg



JK-30 液压螺帽破切器(整体式)
Hydraulic nut cutter

技术参数 TECHNICAL DATA:	
出力(Contribute):	16T
破切范围(Breaking range):	M12-M30
□□□□(Hat to edge):	18-46mm
重量(Weight):	-



YP-24 液压螺帽破切器(整体式)
Hydraulic nut cutter

技术参数 TECHNICAL DATA:	
出力(Contribute):	10T
行程(stroke):	20mm
破切范围(Breaking range):	M8-M24
重量(Weight):	3.15Kg



YP-24B 液压螺帽破切器(分体式)
Hydraulic nut cutter

技术参数 TECHNICAL DATA:	
出力(Contribute):	10T
行程(stroke):	20mm
破切范围(Breaking range):	M8-M24
重量(Weight):	2.5Kg

产品特点:

- 分体式设计, 紧凑, 使用方便
- 独特的角度头设计
- 特殊钢制重型剪切头
- 单作用, 弹簧复位
- 配3/8"牙接头
- 可连接任何输出压力达700bar的液压泵



FEATURES:

- Split design, compact and easy to use
- Special steel heavy shear head
- Equipped with 3/8" adapter
- Any hydraulic pump with an output pressure of 700bar can be connected
- Unique angle head design
- Single acting, spring return

NC-SERIES 液压螺帽破切器(分体式)
Hydraulic nut cutter

技术参数 TECHNICAL DATA:

型号 (Model)	出力 (Output)	螺栓范围 (Bolt range)	六角螺帽范围 (Hexagon nut range)	重量 (Weight)
NC-1318	5T	M8-M12	10-18	1.2kg
NC-1924	10T	M12-M16	18-24	2.0kg
NC-2432	16T	M16-M22	24-32	3.0kg
NC-3241	20T	M22-M27	32-41	4.4kg
NC-4150	30T	M27-M33	41-50	8.2kg
NC-5060	50T	M33-M39	50-60	11.8kg
NC-6075	80T	M39-M48	60-75	34.1kg



JK-27F 液压螺帽破切器(分体式)
Hydraulic nut cutter

技术参数 TECHNICAL DATA:	
出力(Contribute):	11T
破切范围(Breaking range):	M10-M27
□□□□(Hat to edge):	16-41mm
重量(Weight):	4.0Kg



JK-30F 液压螺帽破切器(分体式)
Hydraulic nut cutter

技术参数 TECHNICAL DATA:	
出力(Contribute):	16T
破切范围(Breaking range):	M12-M30
□□□□(Hat to edge):	18-46mm
重量(Weight):	-

液压开孔器

HYDRAULIC HOLE OPENER



液压开孔器

HYDRAULIC HOLE OPENER

卓越品质 精心所制

卓越品质 精心所制



SYD-25 整体式桥梁开孔器

技术参数 TECHNICAL DATA:	
出力(Output):	8T
喉深(Depth of throat):	70mm (模具中心到端面距离)
不锈钢(Stainless steel):	≤1mm
铁板(Iron steel):	≤1.5mm
重量(Weight):	4.75Kg
配件ACCESSORIES:	
模具(Crimping die):	Φ16, Φ20, Φ22, Φ25, Φ28, Φ32mm



SYD-25F 分体式桥梁开孔器

技术参数 TECHNICAL DATA:	
出力(Output):	8T
喉深(Depth of throat):	70mm (模具中心到端面距离)
不锈钢(Stainless steel):	≤1mm
铁板(Iron steel):	≤1.5mm
重量(Weight):	4.3Kg
配件ACCESSORIES:	
模具(Crimping die):	Φ16, Φ20, Φ22, Φ25, Φ28, Φ32mm



SYD-32 整体式桥梁开孔器

技术参数 TECHNICAL DATA:	
出力(Output):	8T
喉深(Depth of throat):	70mm (模具中心到端面距离)
不锈钢(Stainless steel):	≤1.5mm
铁板(Iron steel):	≤2.5mm
重量(Weight):	5.2Kg
配件ACCESSORIES:	
模具(Crimping die):	Φ16, Φ20, Φ22, Φ25, Φ28, Φ32mm



SYD-32F 分体式桥梁开孔器

技术参数 TECHNICAL DATA:	
出力(Output):	8T
喉深(Depth of throat):	70mm (模具中心到端面距离)
不锈钢(Stainless steel):	≤1mm
铁板(Iron steel):	≤2mm
重量(Weight):	5.2Kg
配件ACCESSORIES:	
模具(Crimping die):	Φ16, Φ20, Φ22, Φ25, Φ28, Φ32mm

产品特点:

- 分体式结构, 弹簧回位
- 加工不受场地、位置限制
- 包含手动液压泵、0.8米高压油管

FEATURES:

- Split structure, spring return
- Processing is not restricted by sites and location
- Including manual hydraulic pump, 0.8m high pressure oil pipe



SYK-SERIES 分体式液压开孔器

技术参数 TECHNICAL DATA:							
型号 (Model)	出力 (Motor type)	最大行程 (Max. strokes)	不锈钢厚度 (Stainless steel thickness)	铁板厚度 (Thickness of iron plates)	开孔范围 (Opening range)	开孔范围 (Opening range)	重量 (Weight)
SYK-8A	8T	22mm	1.6mm	3mm	Φ16-Φ51mm	Φ16, Φ20, Φ26.2, Φ32.6, Φ39, Φ51	11Kg
SYK-8B	8T	22mm	1.6mm	3mm	Φ22-Φ60mm	Φ22, Φ27.5, Φ34, Φ43, Φ49, Φ60	11Kg
SYK-15	15T	22mm	2mm	4mm	Φ16-Φ114mm	Φ16, Φ20, Φ26.2, Φ32.6, Φ39, Φ51, Φ22, Φ27.5, Φ34, Φ43, Φ49, Φ60, Φ63, Φ76, Φ80, Φ89, Φ101, Φ114	27Kg

圆模 Round mold

技术参数 TECHNICAL DATA:	
圆模(Round mould):	Φ16-Φ320以上范围内都可定制 Customized within the range of Φ16-Φ320 or above
备注(Notes):	可定制各类尺寸非标模具Can customize various sizes of non-standard mold



2个螺栓, 1个垫圈(2 bolts, 1 washer)



方模 Square mold

技术参数 TECHNICAL DATA:	
方模(Square mould):	MS 45mm*45mm MS 67mm*67mm MS 78mm*78mm MS 92mm*46mm MS 92mm*92mm MS 114mm*114mm
备注(Notes):	可定制各类尺寸非标模具Can customize various sizes of non-standard mold



液压开孔器

HYDRAULIC HOLE OPENER



液压开孔器

HYDRAULIC HOLE OPENER

两种接头供您选择

- ZG3/8"快速接头:适用于原来自已有泵的接头为3/8的
- 14×1.5快速接头:适用于购买过本厂的产品,只需换头部的



ZG3/8"快速接头



14×1.5快速接头



产品特点:

- 铝合金材料的头部和缸体使产品轻便易携带
- 可依客户需求订做圆模和方模(务必量出正确所需尺寸)
- 适用于已烤漆的配电柜、开关箱、钣金整体,产品可灵活更换模具穿孔完毕不会损坏表面。

FEATURES:

- Aluminum alloy head and cylinder make the product light and easy to carry
- Round molds and square molds can be customized according to customer needs (be sure to measure the correct required size)
- Applicable to painted distribution cabinets, switch boxes, sheet metal as a whole, the product can be flexibly replaced with molds
- The surface will not be damaged after perforation.

TP-8C 液压开孔器 Hydraulic punch driver

技术参数 TECHNICAL DATA:

开孔范围(Cutting range):	可在3mm以下软钢板上开孔,最大可开6L5直径
最大开孔力(Puncting force):	6T
行程(Stroke):	22mm
尺寸(Size):	375×70×150mm
包装(Package):	塑料箱 plastic case
重量(Weight):	1.74Kg

配件 ACCESSORIES:

模具(Crimping die):	Φ22, Φ27.5, Φ34.3, Φ43, Φ49, Φ60.8mm
-------------------	--------------------------------------



WK-8C 液压开孔器 Hydraulic punch driver

技术参数 TECHNICAL DATA:

开孔范围(Cutting range):	可在3mm以下软钢板上开孔,最大可开6L5直径
最大开孔力(Puncting force):	8T
行程(Stroke):	25mm
尺寸(Size):	425×95×125mm
包装(Package):	塑料箱 plastic case
重量(Weight):	2.37Kg

配件 ACCESSORIES:

模具(Crimping die):	Φ22, Φ27.5, Φ34.3, Φ43, Φ49, Φ60.8mm
-------------------	--------------------------------------



TPA-8 液压开孔器 Hydraulic punch driver

技术参数 TECHNICAL DATA:

开孔范围(Cutting range):	可在3mm以下软钢板上开孔,最大可开6L5直径
最大开孔力(Puncting force):	6T
行程(Stroke):	22mm
尺寸(Size):	337×70×135mm
包装(Package):	塑料箱 plastic case
重量(Weight):	1.98Kg

配件 ACCESSORIES:

模具(Crimping die):	Φ22, Φ27.5, Φ34.3, Φ43, Φ49, Φ60.8mm
-------------------	--------------------------------------



SYK-8 液压开孔器(头部) Hydraulic punch driver

技术参数 TECHNICAL DATA:

开孔范围(Cutting range):	圆模:Φ16-Φ60mm,方模:≤68×68mm
最大开孔力(Puncting force):	8T
行程(Stroke):	22mm
最大厚度(Max.thickness):	不锈钢≤1.6mm,铁板≤3mm
重量(Weight):	2Kg



SYK-15 液压开孔器(头部) Hydraulic punch driver

技术参数 TECHNICAL DATA:

开孔范围(Cutting range):	圆模:Φ16-Φ114mm,方模:≤113×113mm
最大开孔力(Puncting force):	15T
行程(Stroke):	22mm
最大厚度(Max.thickness):	不锈钢≤2mm,铁板≤4mm
重量(Weight):	3Kg



SYK-30 液压开孔器(头部) Hydraulic punch driver

技术参数 TECHNICAL DATA:

开孔范围(Cutting range):	圆模:Φ110-Φ250mm,方模:≤280×280mm
最大开孔力(Puncting force):	60T
行程(Stroke):	29mm
最大厚度(Max.thickness):	不锈钢≤2mm,铁板≤4mm
重量(Weight):	9.3Kg



电动液压冲孔机

HYDRAULIC PUNCHING TOOLS



电动液压冲孔机

HYDRAULIC PUNCHING TOOLS

产品特点:

- 适用于铁铜铝排等金属材料之冲孔作业;
- 冲孔速度快, 定位准确不偏移;
- 液压冲孔可以免除钻孔时产生的切屑, 作业时较为安全以及更清洁;
- 可携带到现场或是固定于工厂内进行大批量的冲孔作业;
- 主要使用在外墙干挂打孔上, 小空间可以作业优势。

FEATURES:

- Suitable for punching iron copper aluminum bar and other metal materials;
- Fast punching speed, accurate positioning does not offset;
- Hydraulic punching can eliminate the chip produced when drilling, the operation is safer and cleaner;
- Can be carried to the site or fixed in the factory for mass punching operations;
- Mainly used in the external wall dry hanging punching, small space can work advantage.

MHP-20 电动冲孔机(角钢款)

Electric punching machine

技术参数 TECHNICAL DATA:	
出力(Crimping force):	10T
喉深(Depth of throat):	40mm (模具中心到里面距离)
铜铝排(Cu/Al row):	≤8mm
铁板(Iron steel):	≤6mm
角铁(Angle Iron):	4-6#
电压(Voltage):	220V/110V
功率(Power):	1300W
重量(Weight):	12Kg(Contains Iron box 20Kg)
配件ACCESSORIES:	
模具(Crimping die):	Φ8.5, Φ9, Φ13, Φ17, Φ20.5 可定制非标模具≤20.5



角钢长款

角钢短款

产品特点:

- 适用于铁铜铝排等金属材料之冲孔作业;
- 冲孔速度快, 定位准确不偏移;
- 液压冲孔可以免除钻孔时产生的切屑, 作业时较为安全以及更清洁;
- 可携带到现场或是固定于工厂内进行大批量的冲孔作业;
- 主要使用在外墙干挂打孔上, 小空间可以作业优势。

FEATURES:

- Suitable for punching iron copper aluminum bar and other metal materials;
- Fast punching speed, accurate positioning does not offset;
- Hydraulic punching can eliminate the chip produced when drilling, the operation is safer and cleaner;
- Can be carried to the site or fixed in the factory for mass punching operations;
- Mainly used in the external wall dry hanging punching, small space can work advantage.

MHP-20 电动冲孔机(槽钢款)

Electric punching machine

技术参数 TECHNICAL DATA:	
出力(Crimping force):	10T
喉深(Depth of throat):	53mm (模具中心到里面距离)
铜铝排(Cu/Al row):	≤8mm
铁板(Iron steel):	≤6mm
角铁(Angle Iron):	4-6#
槽钢(U-bar)	10#
电压(Voltage):	220V/110V
功率(Power):	1300W
重量(Weight):	12Kg(Contains Iron box 20Kg)
配件ACCESSORIES:	
模具(Crimping die):	Φ8.5, Φ9, Φ13, Φ17, Φ20.5 可定制非标模具≤20.5



槽钢长款

槽钢短款

产品特点:

- 适用于铁铜铝排等金属材料之冲孔作业;
- 冲孔速度快, 定位准确不偏移;
- 液压冲孔可以免除钻孔时产生的切屑, 作业时较为安全以及更清洁;
- 可携带到现场或是固定于工厂内进行大批量的冲孔作业;
- 主要使用在外墙干挂打孔上, 小空间可以作业优势。

FEATURES:

- Suitable for punching iron copper aluminum bar and other metal materials;
- Fast punching speed, accurate positioning does not offset;
- Hydraulic punching can eliminate the chip produced when drilling, the operation is safer and cleaner;
- Can be carried to the site or fixed in the factory for mass punching operations;
- Mainly used in the external wall dry hanging punching, small space can work advantage.

MNP-20C 电动冲孔机(角钢款)

Electric punching machine

技术参数 TECHNICAL DATA:	
出力(Crimping force):	20T
喉深(Depth of throat):	55mm (模具中心到里面距离)
铜铝排(Cu/Al row):	≤10mm
铁板(Iron steel):	≤8mm
角铁(Angle Iron):	3-8#
电压(Voltage):	220V/110V
功率(Power):	1400W
重量(Weight):	14Kg
配件ACCESSORIES:	
模具(Crimping die):	Φ8.5, Φ9, Φ13, Φ17, Φ20.5 可定制非标模具≤20.5



产品特点:

- 适用于铁铜铝排等金属材料之冲孔作业;
- 冲孔速度快, 定位准确不偏移;
- 液压冲孔可以免除钻孔时产生的切屑, 作业时较为安全以及更清洁;
- 可携带到现场或是固定于工厂内进行大批量的冲孔作业;
- 主要使用在外墙干挂打孔上, 小空间可以作业优势。

FEATURES:

- Suitable for punching iron copper aluminum bar and other metal materials;
- Fast punching speed, accurate positioning does not offset;
- Hydraulic punching can eliminate the chip produced when drilling, the operation is safer and cleaner;
- Can be carried to the site or fixed in the factory for mass punching operations;
- Mainly used in the external wall dry hanging punching, small space can work advantage.

MNP-20C 电动冲孔机(槽钢款)

Electric punching machine

技术参数 TECHNICAL DATA:	
出力(Crimping force):	20T
喉深(Depth of throat):	55mm (模具中心到里面距离)
铜铝排(Cu/Al row):	≤10mm
铁板(Iron steel):	≤8mm
角铁(Angle Iron):	3-8#
槽钢(U-bar)	5-10# (槽钢宽度) 8-10# (槽钢厚度)
电压(Voltage):	220V/110V
功率(Power):	1400W
重量(Weight):	14Kg
配件ACCESSORIES:	
模具(Crimping die):	Φ8.5, Φ9, Φ13, Φ17, Φ20.5 可定制非标模具≤20.5



电动液压冲孔机/钢筋切断机

HYDRAULIC PUNCHING TOOLS/BAR CROPPER



电动角铁加工机

ELECTRIC ANGLE IRON PROCESSOR

产品特点:

- 适用光伏支架打孔, 成型钢, 槽钢, 工字钢打孔作业;
- 冲孔速度快, 定位准确不偏移;
- 液压冲孔可以免除钻孔时产生的切屑, 作业时较为安全以及更清洁;
- 可携带到现场或是固定于工厂内进行大批量的冲孔作业;

FEATURES:

- Suitable for photovoltaic bracket punching, forming steel, groove steel, I-steel drilling operation;
- Fast punching speed, accurate positioning and no offset;
- Hydraulic punching can avoid the cutting produced during drilling and operation
- Safe and cleaner;
- Can be carried to the site or fixed in the factory for bulk punching operations;



MHP-20 电动冲孔机(光伏款)

Electric punching machine

技术参数 TECHNICAL DATA:	
出力(Crimping force):	10T
喉深(Depth of throat):	40mm (模具中心到型面距离)
铁/钢板(Iron steel):	≤2.5mm
C型钢(C merchant steel):	41*41*(1.5-2.5)
电压(Voltage):	220V/110V
功率(Power):	1300W
重量(Weight):	13Kg(Contains iron box 16Kg)
配件 ACCESSORIES:	
模具(Crimping die):	Φ8, Φ10, Φ11, Φ12, Φ13 可定制非标模具

产品特点:

- 用于建筑行业使用的平切或自由切割钢筋、线圈杆和全螺纹杆
- 切割刃锯是为快速高效切割各种黑色和有色金属材料而开发的电动工具

FEATURES:

- For flat or free-cut rebar, coil rods and fully threaded bars used in the construction industry
- The cutting blade saw is a power tool developed for rapid and efficient cutting of a variety of black and non-ferrous metal materials



FC-40 电动手持式冷切锯

Electric handheld cold-cut saw

技术参数 TECHNICAL DATA:	
功率(Power):	900W
切断范围(Cut off the range):	Φ40mm3级钢筋, Φ40mm管, Φ40mm O.D. 铜水管, Φ40mm O.D. 油管, Φ40mm 号管, 38mm 方形钢管以及高达30mm O.D. 全螺纹或螺柱
电压(Voltage):	220V/50Hz
机器尺寸(Machine size):	420*165*110mm
净重/毛重(Weight):	3.8Kg/6.5Kg

产品特点:

- 电动角钢切断机适用于切断角钢, 切断省力, 切面光滑, 无铁屑, 轻松不费力, 无需配泵, 模具可定制, 携带方便, 应用于桥梁, 钢结构, 高压配电塔等现场作业, 或者固定厂内进行批量生产。

FEATURES:

- Electric angle steel cutting machine is suitable for cutting angle steel, cutting labor-saving, smooth cut surface, no iron filings, easy and effortless, no need to match pump, mold can be customized, easy to carry, used in bridge, steel frame structure, high-voltage power tower and other field operations or mass production in a fixed plant.

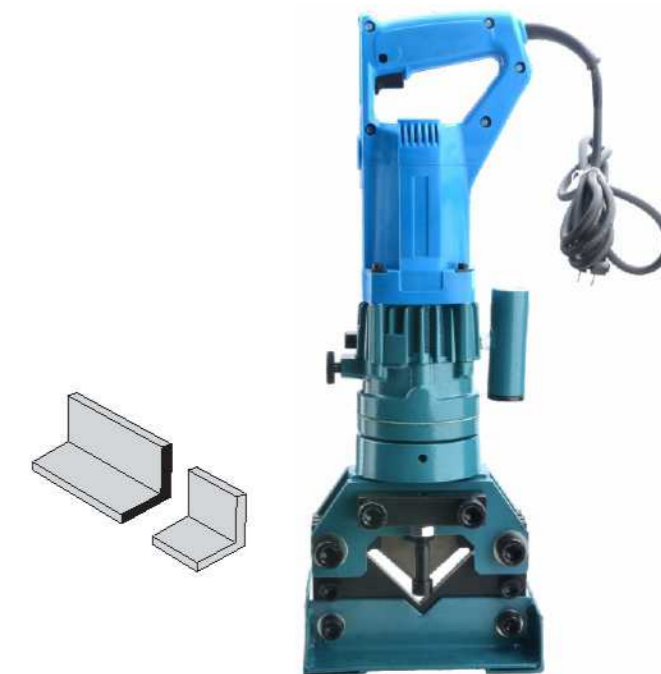

MH-60 电动角钢切断机

Electric angle steel cutting machine

技术参数 TECHNICAL DATA:	
电机功率(Motor power):	1300W
最大切断大小(Max. cut size):	80*80mm (角钢)
最大铁板厚度(Max. sheet thickness):	8mm
电压(Voltage):	110V/220V/230V
频率(Frequency):	50/60Hz
净重/毛重(Weight):	17.5Kg/22Kg

产品特点:

- 角钢圆弧倒角机携带方便, 适用于角钢圆弧倒角切角作业, 一面切圆角, 一面切斜角, 切断快速, 无铁屑, 表面光滑, 体积小, 重量轻, 易于操作, 多场景现场作业等优点。

FEATURES:

- Tool description: Easy to carry, suitable for Angle steel arc chamfering cutting operation, one side cut round corner, one side cut bevel Angle, cutting fast, no iron chips, smooth surface, small volume, light weight, easy to operate, multi-scene field operation and other advantages.



MH-60 电动角钢切角机

Electric angle steel angle cutter

技术参数 TECHNICAL DATA:	
电机功率(Motor power):	1300W
最大切断大小(Max. cut size):	斜角: 5#以下角钢 圆弧角: 6#以下角钢
最大铁板厚度(Max. sheet thickness):	8mm
电压(Voltage):	110V/220V/230V
频率(Frequency):	50/60Hz
净重/毛重(Weight):	15Kg/17Kg

电动角铁加工机

ELECTRIC ANGLE IRON PROCESSOR



电动角铁加工机

ELECTRIC ANGLE IRON PROCESSOR

产品特点:

电动圆弧倒角切角机适用于铁、铜、铝板、角钢切角作业,角度近似90度,切断快速,无铁屑,表面光滑,体积小,重量轻,携带方便,易于操作,多场景现场作业等优点。

FEATURES:

Electric circular arc chamfering cutting machine is suitable for iron, copper, aluminum plate, Angle steel cutting operation, the Angle is similar to 90 degrees, fast cut off, no iron chips, smooth surface, small volume, light weight, easy to carry, easy to operate, multi-scene field operation and other advantages.



MH-60 电动角钢切角机

Electric angle steel angle cutter

技术参数 TECHNICAL DATA:	
电机功率(Motor power):	1300W
最大切断大小(Max.cut size):	斜角: 5#以下角钢 圆弧角: 6#以下角钢
最大铁板厚度(Max.sheet thickness):	6mm
电压(Voltage):	110V/220V/230V
频率(Frequency):	50/60Hz
净重/毛重(Weight):	18Kg/20Kg

产品特点:

大容量锂电池,多重智能保护功能持久续航,大功率强劲电机,强劲动力同时更静音,携带方便,适用于铁,铜,铝板,成型钢,槽钢,工字钢打孔作业,体积小,重量轻,易于操作,省力且快速冲孔等优点。定位精准不偏移;可以操作各种形状的冲孔模;液压冲孔可以免除钻孔时产生的切屑,作业时安全稳定更清洁;可携带到现场进行冲孔作业;主要使用在外墙干挂打孔上,小空间可以作业优势。

FEATURES:

Large capacity lithium battery, multiple intelligent protection function lasting endurance, high power strong motor, strong power at the same time more silent, easy to carry, suitable for iron, copper, aluminum plate, forming steel, groove steel, I-steel drilling operation, small volume, light weight, easy to operate, labor saving and quick punching and other advantages. Accurate positioning is not offset; can operate various shapes of punching die; hydraulic punching can avoid the cutting produced during drilling, safe, stable and cleaner during operation; can be carried to the site for punching work; mainly used in the external wall dry hanging punching, small space can work advantages.



LD-20 充电式冲孔机

Battery powered hole puncher

技术参数 TECHNICAL DATA:		
出力(Crimping force):	角钢款	槽钢款
喉深(Depth of throat): (模具中心到压面距离)	40mm	40mm
铜铝棒(Cu/Al rod):	≤8mm	≤8mm
铁板(Iron steel):	≤6mm	≤6mm
槽钢(Channel steel):	—	8-10#
电池电压(Voltage):	36V	36V
功率(Power):	1500W	1500W
重量(Weight): (不含包装)	12Kg	12Kg
配件 ACCESSORIES:		
模具(Crimping die):	Φ8.5, Φ8, Φ13, Φ17, Φ20.5	
电池(Battery):	2块(pcs)	2块(pcs)
充电器(Charger):	1个(pc)	1个(pc)
密封件(Sealing element):	1套(set)	1套(set)

产品特点:

大容量锂电池,多重智能保护功能持久续航,大功率强劲电机,强劲动力同时更静音,携带方便,适用于铁,铜,铝板,角钢切角作业,角度近似90度,切断快速,无铁屑,表面光滑,体积小,重量轻,易于操作,多场景现场作业等优点。

FEATURES:

Large capacity lithium battery, multiple intelligent protection function lasting endurance, high power motor, strong power at the same time more quiet, easy to carry, suitable for iron, copper aluminum plate, Angle steel cutting operation, Angle approximately 90 degrees cutting fast without iron chips, smooth surface, small volume, light weight, easy to operate multi-scene field operations and other advantages.

LD-60 充电式角钢切角机

Battery angle steel cutting machine

技术参数 TECHNICAL DATA:	
电机功率(Motor power):	1500W
出力(Output):	16T
最大切断大小(Max.cut size):	60*60mm (角钢)
最大铁板厚度(Max.sheet thickness):	6mm
切断速度(Cutting speed):	2S-3S
电池电压(Voltage):	36V
电池容量(Capacity):	6.0Ah
充电时间(Charging time):	2 hours
配件 ACCESSORIES:	
电池(Battery):	2块(pcs)
充电器(Charger):	1个(pc)
密封件(Sealing element):	1套(set)



产品特点:

大容量锂电池,多重智能保护功能持久续航,大功率强劲电机,强劲动力同时更静音,携带方便,适用于角钢圆弧倒角作业,一面切圆角,一面切斜角,切断快速,无铁屑,表面光滑,体积小,重量轻,易于操作,多场景现场作业等优点。

FEATURES:

Large capacity lithium battery, multiple intelligent protection function lasting endurance, high power motor, strong power at the same time more quiet, easy to carry, suitable for Angle steel arc chamfering cutting operation, one side cut round corner, one side cut bevel, cutting fast, no iron shavings smooth surface, small volume, light weight, easy to operate multi-scene field operations and other advantages.

LD-60 充电式角钢切角机

Battery angle steel cutting machine

技术参数 TECHNICAL DATA:	
电机功率(Motor power):	1500W
出力(Output):	16T
最大切断大小(Max.cut size):	斜角: 5#以下角钢 圆弧角: 6#以下角钢
最大铁板厚度(Max.sheet thickness):	6mm
切断速度(Cutting speed):	2S-3S
电池电压(Voltage):	36V
电池容量(Capacity):	6.0Ah
充电时间(Charging time):	2 hours
配件 ACCESSORIES:	
电池(Battery):	2块(pcs)
充电器(Charger):	1个(pc)
密封件(Sealing element):	1套(set)



液压冲孔机

HYDRAULIC PUNCHING TOOLS



液压冲孔机

HYDRAULIC PUNCHING TOOLS

卓越品质 精心所制

卓越品质 精心所制



CH-60 分体式液压冲孔机

Hydraulic punching tools

技术参数 TECHNICAL DATA:	
出力(Output):	31T
喉深(Depth of throat):	95mm
角钢(Angle steel):	4-8#
槽钢(Channel steel):	8-10#(宽面)
铜铝排(Cu and Al bus):	3-10mm
铁板(Iron plate):	3-8mm
重量(Weight):	20Kg
配件ACCESSORIES:	
模具(Crimping die):	Φ10.5, Φ13.8, Φ17.5, Φ20.5mm



CH-60L 分体式液压冲孔机(角铁款)

Hydraulic punching tools(Angle Iron)

技术参数 TECHNICAL DATA:	
出力(Output):	31T
喉深(Depth of throat):	95mm
角钢(Angle steel):	3-8#
槽钢(Channel steel):	8-10#(宽面)
铜铝排(Cu and Al bus):	3-10mm
铁板(Iron plate):	3-8mm
重量(Weight):	20Kg
配件ACCESSORIES:	
模具(Crimping die):	Φ10.5, Φ13.8, Φ17.5, Φ20.5mm



CKJ-21 便携式机械打孔机

Portable mechanical punching machine

技术参数 TECHNICAL DATA:	
吨位(tonnage):	20T
喉深(Depth of throat):	72mm
手压力(Lever force):	<0.25KN
铜铝板(Cu/Al plate):	4-9mm
角铁/扁铁/不锈钢 (Angle iron/flat iron/stainless steel):	4-8mm
开孔范围(Opening range):	≤Φ11-Φ21
重量(Weight):	15.4Kg
配件ACCESSORIES:	
模具(Crimping die):	Φ13, Φ15, Φ17, Φ19, Φ21mm



SH-70A 分体式液压冲孔机

Hydraulic punching tools

技术参数 TECHNICAL DATA:	
出力(Output):	31T
喉深(Depth of throat):	80mm
铜铝排(Cu and Al bus):	3-13mm
铁板(Iron plate):	3-10mm
重量(Weight):	15.25Kg
配件ACCESSORIES:	
模具(Crimping die):	Φ10.5, Φ13.8, Φ17.5, Φ20.5mm



CH-70 分体式液压冲孔机

Hydraulic punching tools

技术参数 TECHNICAL DATA:	
出力(Output):	35T
喉深(Depth of throat):	110mm
角钢(Angle steel):	5-10#
槽钢(Channel steel):	8-12#(宽面)
铜铝排(Cu and Al bus):	3-12mm
铁板(Iron plate):	3-10mm
重量(Weight):	35Kg
配件ACCESSORIES:	
模具(Crimping die):	Φ10.5, Φ13.8, Φ17.5, Φ20.5mm



CH-70L 分体式液压冲孔机(角铁款)

Hydraulic punching tools(Angle iron)

技术参数 TECHNICAL DATA:	
出力(Output):	35T
喉深(Depth of throat):	110mm
角钢(Angle steel):	5-10#
槽钢(Channel steel):	8-12#(宽面)
铜铝排(Cu and Al bus):	3-12mm
铁板(Iron plate):	3-10mm
重量(Weight):	34Kg
配件ACCESSORIES:	
模具(Crimping die):	Φ10.5, Φ13.8, Φ17.5, Φ20.5mm



Z型钢C型钢冲孔机

CKG-18570 分体式液压冲孔机

Hydraulic punching tools

技术参数 TECHNICAL DATA:	
出力(Output):	8T
喉深(Depth of throat):	190mm (模具中心到压面距离)
孔径(Aperture):	Φ6-22mm
铁板(Iron plate):	厚≤3mm
不锈钢(Stainless steel):	厚≤2mm
重量(Weight):	13.8Kg
配件ACCESSORIES:	
模具(Crimping die):	Φ12mm(模具可选配6-22mm)



单回路

双回路

槽钢三面冲

CH-75 分体式液压冲孔机

Hydraulic punching tools

技术参数 TECHNICAL DATA:	
出力(Output):	35T
喉深(Depth of throat):	80mm (模具中心到压面距离)
铁板(Iron plate):	≤5mm厚
角钢(Angle steel):	3-5#
槽钢(Channel steel):	6-12#
重量(Weight):	44.7Kg
配件ACCESSORIES:	
模具(Crimping die):	Φ10.5, Φ13.8, Φ17.5, Φ20.5mm

液压冲孔机

HYDRAULIC PUNCHING TOOLS



液压切排机

HYDRAULIC BRASS CUTTER



CH-80A 分体式液压冲孔机

技术参数 TECHNICAL DATA:	
出力(Output):	55T
喉深(Depth of throat):	120mm
铁板(Iron plate):	≤16mm
角钢(Angle steel):	8-12#
槽钢(Channel steel):	6-16#(宽面)
重量(Weight):	82/85Kg
配件ACCESSORIES:	
模具(Crimping die):	Φ16, Φ18, Φ22, Φ25mm



CH-80H 分体式液压冲孔机

技术参数 TECHNICAL DATA:	
出力(Output):	55T
喉深(Depth of throat):	120mm
铁板(Iron plate):	≤16mm
角钢(Angle steel):	8-12#
槽钢(Channel steel):	6-16#(宽面)
H型钢(H-beam):	8-15#
重量(Weight):	82/85Kg
配件ACCESSORIES:	
模具(Crimping die):	Φ16, Φ18, Φ22, Φ25mm



CH-100A 分体式液压冲孔机

技术参数 TECHNICAL DATA:	
出力(Output):	100T
喉深(Depth of throat):	136mm
铁板(Iron plate):	≤20mm
角钢(Angle steel):	8-16#
槽钢(Channel steel):	10-15#(宽面)
重量(Weight):	170/180Kg
配件ACCESSORIES:	
模具(Crimping die):	Φ22, Φ25, Φ28, Φ32mm



CH-100H 分体式液压冲孔机

技术参数 TECHNICAL DATA:	
出力(Output):	100T
喉深(Depth of throat):	136mm
铁板(Iron plate):	≤20mm
角钢(Angle steel):	8-16#
槽钢(Channel steel):	10-15#(宽面)
H型钢(H-beam):	10-15#
重量(Weight):	170/180Kg
配件ACCESSORIES:	
模具(Crimping die):	Φ22, Φ25, Φ28, Φ32mm

产品特点:

- 适用于铜铝排等金属材料的切断作业,需搭配手动、电动泵浦使用
- 切断速度快,无噪音,无细小碎屑,切口平整不变形
- 可携带到现场或是固定于工厂内进行大批量的切断作业
- 配置3/8接头和防尘帽,可连接各式压力液压泵

FEATURES:

- It is suitable for cutting off metal materials such as copper and aluminum bars. It needs to be used with manual and electric pumps
- Fast cutting speed, no noise, no small debris, flat cut without deformation
- It can be carried to the site or fixed in the factory for mass cutting operation
- Equipped with 3/8 connector and dust cap, it can connect various pressure hydraulic pumps



CWC-150 液压切排机

技术参数 TECHNICAL DATA:	
出力(Output):	20T
板厚(Thickness of sheet):	3-10mm
宽度(Width of sheet):	≤150mm
尺寸(Size):	410×270×150mm
重量(Weight):	31.7kg



CWC-200 液压切排机

技术参数 TECHNICAL DATA:	
出力(Output):	25T
板厚(Thickness of sheet):	3-12mm
宽度(Width of sheet):	≤200mm
尺寸(Size):	420×320×150mm
重量(Weight):	36.8kg



CWC-150V 液压切排机

技术参数 TECHNICAL DATA:	
出力(Output):	20T
板厚(Thickness of sheet):	3-10mm (有废料, 板材不变形)
宽度(Width of sheet):	≤150mm
尺寸(Size):	410×270×150mm
重量(Weight):	29kg



CWC-200V 液压切排机

技术参数 TECHNICAL DATA:	
出力(Output):	25T
板厚(Thickness of sheet):	3-12mm (有废料, 板材不变形)
宽度(Width of sheet):	≤200mm
尺寸(Size):	420×320×150mm
重量(Weight):	34kg

液压弯排机

HYDRAULIC BENDING MACHINE



液压弯排机

HYDRAULIC BENDING MACHINE

卓越品质 精心所制

卓越品质 精心所制



CB-150D 液压弯排机

Hydraulic bending machine

技术参数 TECHNICAL DATA:	
出力(Output):	16T
板厚(Thickness of sheet):	3-10mm
宽度(Width of sheet):	≤160mm
折弯对象(Bend object):	铜排、铝排
重量(Weight):	19.5kg



CB-200A 液压弯排机

Hydraulic bending machine

技术参数 TECHNICAL DATA:	
出力(Output):	25T
板厚(Thickness of sheet):	3-12mm
宽度(Width of sheet):	≤200mm
折弯对象(Bend object):	铜排、铝排
重量(Weight):	25kg



PLW-125 二合一平立弯排机

2 in 1 vertical and level busbar bender

形式 Form	出力 Output (T)	重量 Weight (Kg)	高度 Height (mm)	尺寸 Size (mm)	最大铜排宽度 Max.width (mm)	最大铜排厚度 Max.thickness (mm)	机体重量 Body weight (mm)	立弯模具配件 Vertical bending tool accessories (mm)	平弯模具配件 Flat bending accessories (mm)
单回路油缸式 (single action oil pressure type)	35	90	290	机座宽度680 Machine seat width 680 加排缸总长770 Total length of oil fitting cylinder 770	40,50,60,80,100,125	4,6,8,10,12	90kg(机翼+油缸及上下板模各一只) (One wing + oil cylinder and one upper and lower die)	模具×7,靠轮座×2 插销×2,衬套×4 Die×7, Wheel seat×2 Bolt×2, Lining bar×4	上下模具×1 固定螺母×2 弯曲角度90° Upper and lower die×1 Fixed bolt×2 Bending angle 90°
铜排厚度 Thickness of copper bus bar (mm)	铜排宽度 Width of copper bus bar (mm)	组件弯曲模具 Component bending die	弯曲角度 Bending angle	弯曲R内径 Bending shape R inner radian					
4mm	40,50,60	1	90°	110mm					
5mm	80	1	90°	140mm					
6mm	80	1	90°	140mm					
8mm	100	1	90°	160mm					
10mm	100	1	90°	160mm					
10mm	125	1	90°	160mm					
12mm	125	1	90°	160mm					

注: 1.中碳钢材料 Medium carbon steel material 2.模具中碳钢制上下压板 Die medium carbon steel upper/lower press plate

产品特点:

- 集铜排/铝排立弯、平弯一体两用设计, 弯曲弧度符合国家标准, 平滑无皱, 无扭曲变形
- 机体板采用无焊接铰链式, 坚固耐用, 无断裂, 开合轻巧方便
- 独特的曲板弯曲刻度设计, 一次弯曲成型, 精度高
- 模具快速组装拆卸, 底部安装滚轮, 现场移动更方便

FEATURES:

- Set copper row / aluminum row vertical bending, flat bending integrated design, bending radian in line with the national standards, smooth without wrinkle, no distortion deformation
- The body plate is unwelded hinge type, durable, no break, light and easy to open and close
- Unique curved plate bending scale design, one bending molding, high precision
- Mold fast assembly and disassembly, the bottom installation roller, field movement is more convenient



SWP-10A 二合一平立弯排机(整体式)

2 in 1 vertical and level busbar bender

技术参数 TECHNICAL DATA:	
弯曲角度(Bending angle):	≥90°
弯曲厚度(Bending thickness):	4-10mm
最大压力(Max.pressure):	65Mpa
最大行程(Max.stroke):	250mm
弯曲半径(Bending radius):	2.5倍排宽
弯曲范围(Bending range):	铜铝排宽度:40,50,80,80,100,120mm
配件ACCESSORIES:	
模具(Crimping die):	40×4,40×5,40×6,40×8,60×8,60×10,80×6,100×8,100×10

产品特点:

- 集铜排/铝排立弯、平弯一体两用设计, 弯曲弧度符合国家标准, 平滑无皱, 无扭曲变形
- 机体板采用无焊接铰链式, 坚固耐用, 无断裂, 开合轻巧方便
- 独特的曲板弯曲刻度设计, 一次弯曲成型, 精度高
- 模具快速组装拆卸, 底部安装滚轮, 现场移动更方便
- 配置ZG3/8"快速接头可连接任何输出压力达700bar的液压泵

FEATURES:

- Set copper row / aluminum row vertical bending, flat bending integrated design, bending radian in line with the national standards, smooth without wrinkle, no distortion deformation
- The body plate is unwelded hinge type, durable, no break, light and easy to open and close
- Unique curved plate bending scale design, one bending molding, high precision
- Mold fast assembly and disassembly, the bottom installation roller, field movement is more convenient
- ZG 3/8" is attached to any hydraulic pump with output pressure up to 700bar



SWP-10F 二合一平立弯排机(分体式)

2 in 1 vertical and level busbar bender

技术参数 TECHNICAL DATA:	
弯曲角度(Bending angle):	≥90°
弯曲厚度(Bending thickness):	4-10mm
最大压力(Max.pressure):	65Mpa
最大行程(Max.stroke):	250mm
弯曲半径(Bending radius):	2.5倍排宽
弯曲范围(Bending range):	铜铝排宽度:40,50,80,80,100,120mm
配件ACCESSORIES:	
模具(Crimping die):	40×4,40×5,40×6,40×8,60×8,60×10,80×6,100×8,100×10

液压角铁加工机

HYDRAULIC ANGLE-IRON PROCESSOR



液压角铁加工机

HYDRAULIC ANGLE-IRON PROCESSOR

卓越品质 精心所制

卓越品质 精心所制

产品特点:

- 适用于输配电高压铁塔角钢、桥梁、钢结构等使用角钢的地方。
- 分体式设计, 便于携带, 操作方便。
- 角钢切断器具有快速切断、省力、无噪音、无铁屑、切断面光滑整洁的特点。

FEATURES:

- Suit for the PTD(power transmission and distribution)high pressure iron tower angle iron, bridge, steel structure and etc.
- Split type, easy carry on, easy operation.
- Fast cutting, save power, no noise, no scrap iron, smooth after cutting.



■ CAC-60 液压角钢切断机

技术参数 TECHNICAL DATA:	
出力(Output):	30T
切断厚度(Cut thickness):	≤5mm
切断宽度(Cut off width):	60×60mm
尺寸(Size):	280×250×380mm
重量(Weight):	30kg



■ CAC-75 液压角钢切断机

技术参数 TECHNICAL DATA:	
出力(Output):	20T
切断厚度(Cut thickness):	≤6mm
切断宽度(Cut off width):	75×75mm
尺寸(Size):	270×150×410mm
重量(Weight):	33kg



■ CAC-110 液压角钢切断机

技术参数 TECHNICAL DATA:	
出力(Output):	30T
切断厚度(Cut thickness):	≤10mm
切断宽度(Cut off width):	110×110mm
尺寸(Size):	320×150×450mm
重量(Weight):	41.2kg



■ CAC-160 液压角钢切断机

技术参数 TECHNICAL DATA:	
出力(Output):	100T
切断厚度(Cut thickness):	≤15mm
切断宽度(Cut off width):	150×150mm
尺寸(Size):	400×220×800mm
重量(Weight):	100kg

■ 液压角铁切角机 Hydraulic angle cutting machine

技术参数 TECHNICAL DATA:	
出力(Output):	20T
切断范围(Cut off range):	6号及以下角钢
尺寸(size):	250×206×340mm
重量(Weight):	48kg



■ 液压角铁折角机 Hydraulic angle iron folding machine

技术参数 TECHNICAL DATA:	
出力(Output):	20T
切断范围(Cut off range):	6号及以下角钢
尺寸(size):	300×80×130mm
重量(Weight):	18kg



■ 液压角铁切圆角机 Hydraulic Angle Iron Cutting and Filing Machine

技术参数 TECHNICAL DATA:	
出力(Output):	25T
切断范围(Cut off range):	3-6号角铁
最大板厚(Max. plate thickness):	6mm
重量(Weight):	-

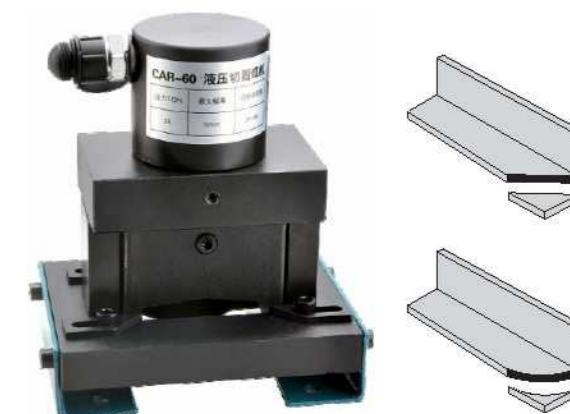

母线加工机

HYDRAULIC BUSBAR PROCESSOR TOOLS



母线加工机

HYDRAULIC BUSBAR PROCESSOR TOOLS

产品特点:

- 本机系参照国外先进产品, 结合国内实际情况, 为提高工作效率, 节省工作时间, 而设计制造
- 适合在大型车间及输配电工作的现场施工, 及配电柜和开关柜等电器制造厂使用
- 本机配有: 折弯、切断、冲孔功能。可选配脚踏开关或线控开关, 操作方便

FEATURES:

- This machine is the light of foreign advanced products, combined with the actual situation in China, in order to improve work efficiency.
- To save hours of work, while the design and manufacture.
- Suitable for transmission and distribution in a large workshop and site work, construction, and power distribution cabinets and switch cabinets, etc.
- The use of electrical appliances factory.
- The machine is equipped with: bending, cutting, punching functionality.
- Optional foot switch or wire switch, easy to operate.

产品特点:

- 本机系参照国外先进产品, 结合国内实际情况, 为提高工作效率, 节省工作时间, 而设计制造
- 适合在大型车间及输配电工作的现场施工, 及配电柜和开关柜等电器制造厂使用
- 本机配有: 折弯、切断、冲孔功能。可选配脚踏开关或线控开关, 操作方便

FEATURES:

- This machine is the light of foreign advanced products, combined with the actual situation in China, in order to improve work efficiency.
- To save hours of work, while the design and manufacture.
- Suitable for transmission and distribution in a large workshop and site work, construction, and power distribution cabinets and switch cabinets, etc.
- The use of electrical appliances factory.
- The machine is equipped with: bending, cutting, punching functionality.
- Optional foot switch or wire switch, easy to operate.

VHB-150D 三合一母线加工机

技术参数 TECHNICAL DATA :	
功能(Functions):	切断, 冲孔, 平弯(Cut, Punch, Bend)
电压(Voltage):	220V/380V
油压(Oil pressure):	700kgf/cm ²
切排机出力(Output of cutting machine):	20T
切排能力(Bus bar cutting capability):	160mm*12mm
冲孔机出力(Output of bus bar cutter):	30T
喉深(Depth of throat):	110mm
标准模具(Standard setting):	Φ7, Φ9, Φ10.5, Φ13.8, Φ17.5, Φ20.5mm
冲孔能力(Punching capacity):	Φ6-Φ20.5mm
弯排机出力(Output of bending machine):	15T
弯排能力(Bending capacity):	150mm*12mm
重量(Weight):	170kg
尺寸(Size):	760*760*1300mm



VHB-501 五合一母线加工机

技术参数 TECHNICAL DATA :	
功能(Functions):	切断, 冲孔, 弯排, 压花(Cut, Punch, Bend, Emboss)
电压(Voltage):	220V/380V
油压(Oil pressure):	700kgf/cm ²
切排机出力(Output of cutting machine):	36T
切排能力(Bus bar cutting capability):	200mm*12mm
冲孔机出力(Output of bus bar cutter):	35T
喉深(Depth of throat):	110mm
标准模具(Standard setting):	Φ7, Φ9, Φ10.5, Φ13.8, Φ17.5, Φ20.5mm
冲孔能力(Punching capacity):	Φ6-Φ20.5mm
弯排机出力(Output of bending machine):	36T
弯排能力(Bending capacity):	125mm*12.5mm
压花机出力(Output of Embosser):	80T
重量(Weight):	280kg
尺寸(Size):	1050*750*1300mm



VHB-200 三合一母线加工机

技术参数 TECHNICAL DATA :	
功能(Functions):	切断, 冲孔, 平弯(Cut, Punch, Bend)
电压(Voltage):	220V/380V
油压(Oil pressure):	700kgf/cm ²
切排机出力(Output of cutting machine):	35T
切排能力(Bus bar cutting capability):	200mm*12mm
冲孔机出力(Output of bus bar cutter):	35T
喉深(Depth of throat):	110mm
标准模具(Standard setting):	Φ7, Φ9, Φ10.5, Φ13.8, Φ17.5, Φ20.5mm
冲孔能力(Punching capacity):	Φ6-Φ20.5mm
弯排机出力(Output of bending machine):	15T
弯排能力(Bending capacity):	200mm*12mm
重量(Weight):	230kg
尺寸(Size):	1050*750*1300mm



XFJGJ 三合一角钢加工机

技术参数 TECHNICAL DATA :	
功能(Functions):	切断, 冲孔, 切角(Cut off, punch, outcorner)
电压(Voltage):	220V/380V
油压(Oil pressure):	700kgf/cm ²
切排机出力(Output of cutting machine):	36T
切排能力(Bus bar cutting capability):	160mm*10mm
冲孔机出力(Output of bus bar cutter):	30T
喉深(Depth of throat):	85mm
标准模具(Standard setting):	Φ10.5, Φ13.8, Φ17.5, Φ20.5mm
冲孔能力(Punching capacity):	Φ10.5-Φ20.5mm
角钢切角出力(Output of bending machine):	35T
切角能力(Bending capacity):	50mm*50mm*5mm
重量(Weight):	170kg



液压母线加工机组合 BUSBAR PROCESSING MACHINE



液压母线加工机组合 BUSBAR PROCESSING MACHINE

卓越品质 精心所制

卓越品质 精心所制

组合 1



组合 2



组合 3



组合 4



组合 5



组合 6



组合 7



组合 8



组合 9



组合 10



组合 11



组合 12



液压弯管机

HYDRAULIC PIPE BENDER



液压弯管机

HYDRAULIC PIPE BENDER



SWG系列 整体式弯管机
Integral bending machine

技术参数 TECHNICAL DATA :

型号 (Model)	出力 (Output)	行程 (Stroke)	弯曲范围 (Bending range)	标配模具 (Standard setting)	管材壁厚 (Pipe wall thickness)	重量 (Weight)	体积 (Volume)
SWG-1	10T	170mm	Φ13-Φ34mm	1/4", 5/16", 3/8", 1/2", 3/4", 1" in	2-3.5mm	22kg	490×250×150mm
SWG-2	13T	250mm	Φ21.3-Φ60mm	1/2", 3/4", 1", 1 1/4", 1 1/2", 2" in	2.75-4.5mm	50kg	730×300×200mm
SWG-3	20T	290mm	Φ21.3-Φ88.5mm	1/2", 3/4", 1", 1 1/4", 1 1/2", 2", 3" in	2.75-6mm	98kg	930×400×210mm
SWG-4	23T	370mm	Φ21.3-Φ108mm	1/2", 3/4", 1", 1 1/4", 1 1/2", 2", 3", 4" in	2.75-6mm	149kg	1180×440×230mm
SWG-1J	10T	170mm	Φ13-Φ34mm	1/4", 5/16", 3/8", 1/2", 3/4", 1" in	2-3.5mm	22kg	490×250×150mm
SWG-2J	13T	250mm	Φ21.3-Φ60mm	1/2", 3/4", 1", 1 1/4", 1 1/2", 2" in	2.75-4.5mm	53kg	730×300×200mm
SWG-3J	20T	290mm	Φ21.3-Φ88.5mm	1/2", 3/4", 1", 1 1/4", 1 1/2", 2", 3" in	2.75-6mm	117kg	930×400×210mm
SWG-4J	23T	370mm	Φ21.3-Φ108mm	1/2", 3/4", 1", 1 1/4", 1 1/2", 2", 3", 4" in	2.75-6mm	165kg	1180×460×230mm
SWG-25S	-	-	Φ10-Φ25mm	3/8", 1/2", 5/16", 3/8", 5/8", 3/4", 7/8", 1" in	0.6-2.0mm	25kg	630×430×180mm



CPB系列 分体式弯管机
SPUT BENDING MACHINE

技术参数 TECHNICAL DATA :

型号 (Model)	出力 (Output)	行程 (Stroke)	弯曲范围 (Bending range)	标配模具 (Standard setting)	管材壁厚 (Pipe wall thickness)	重量 (Weight)	体积 (Volume)
CPB-1F	10T	170mm	Φ13-Φ34mm	1/4", 5/16", 3/8", 1/2", 3/4", 1" in	2-3.5mm	22kg	490×250×150mm
CPB-2F	13T	250mm	Φ21.3-Φ60mm	1/2", 3/4", 1", 1 1/4", 1 1/2", 2" in	2.75-4.5mm	50kg	730×300×200mm
CPB-3F	20T	290mm	Φ21.3-Φ88.5mm	1/2", 3/4", 1", 1 1/4", 1 1/2", 2", 3" in	2.75-6mm	112kg	930×400×210mm
	23T	370mm	Φ21.3-Φ108mm	1/2", 3/4", 1", 1 1/4", 1 1/2", 2", 3", 4" in	2.75-6mm	157kg	1180×460×230mm
FWG-1	10T	170mm	Φ13-Φ34mm	1/4", 5/16", 3/8", 1/2", 3/4", 1" in	2-3.5mm	22kg	490×250×150mm
	9T	250mm	Φ21.3-Φ60mm	1/2", 3/4", 1", 1 1/4", 1 1/2", 2" in	2.75-4.5mm	49kg	730×300×200mm
FWG-3	19T	290mm	Φ21.3-Φ88.5mm	1/2", 3/4", 1", 1 1/4", 1 1/2", 2", 3" in	2.75-6mm	104kg	930×400×210mm
	21T	370mm	Φ21.3-Φ108mm	1/2", 3/4", 1", 1 1/4", 1 1/2", 2", 3", 4" in	2.75-6mm	145kg	1180×440×230mm

产品特点:

适用镀锌管、焊接、无缝钢管、瓦斯管等，不适合弯曲薄壁管，不符合弯曲外径的钢管以及有色金属管

FEATURES:

Suitable for galvanized pipe, welding, seamless steel pipe, gas pipe, etc., not suitable for bending thin wall pipe, Steel pipes and non-ferrous metal pipes that do not meet the curved outer diameter

DWG-2D 电动式弯管机 Electric bending machine

技术参数 TECHNICAL DATA:	
弯曲范围 (Bending range):	Φ21.3-Φ60mm
弯曲角度 (Bending angle):	90° ≤ α ≤ 180°
材料厚度 (Bending thickness):	2.75-3.9mm
电压 (Voltage):	220V
出力 (Output):	13T
行程 (Stroke):	250mm
产品材质 (Product material):	球墨铸铁
配件 ACCESSORIES:	
模具 (Crimping dies):	22, 26, 34, 42, 48, 60mm



产品特点:

该设备是通风安装工程重要机具之一，用于通风管连接法兰的铆接作业，具有生产效率高、快捷方便、设备小巧、操作灵活、噪音小、检修方便等特点

FEATURES:

The equipment is one of the important machines and tools for the construction of ventilation installation engineering, which is used for the riveting operation of ventilation pipe connection flange. It has the characteristics of high production efficiency, fast and convenient, small equipment, flexible operation, small noise and convenient maintenance



单头液压铆钉机 Single-head hydraulic rivet machine

技术参数 TECHNICAL DATA:	
规格 (Output):	单枪
工作压力 (Depth of throat):	20Mpa
功率 (Iron plate):	1600W
工作推力 (Angle steel):	85KN
加工范围 (Channel steel):	3/4, 5# (角钢)
电压 (Channel steel):	220V/380V
外形尺寸 (Channel steel):	510×320×700mm
加工铆钉范围 (Channel steel):	常深4×8, 5×10平头铁铆钉
液压油 (Channel steel):	46#抗磨液压油 16L
重量 (Weight):	70Kg
备注 POUR:	
液压油, 220V机器请使用2.5平方电缆线电源线长度不大于5米, 否则容易烧坏电机	



双头液压铆钉机 Double-head hydraulic rivet machine

技术参数 TECHNICAL DATA:	
规格 (Output):	双枪
工作压力 (Depth of throat):	20Mpa
功率 (Iron plate):	2200W
工作推力 (Angle steel):	85KN
加工范围 (Channel steel):	3/4, 5# (角钢)
电压 (Channel steel):	220V/380V
外形尺寸 (Channel steel):	510×320×700mm
加工铆钉范围 (Channel steel):	常深4×8, 5×10平头铁铆钉
液压油 (Channel steel):	46#抗磨液压油 16L
重量 (Weight):	80Kg
备注 POUR:	
液压油, 220V机器请使用2.5平方电缆线电源线长度不大于5米, 否则容易烧坏电机	

手动液压泵 HYDRAULIC PUMP



手动液压泵 HYDRAULIC PUMP

产品特点:

- 该泵设计有高、低压两段式，出油量快，即使没有电力液可操作，任何工作压力、功能与电动式相同
- 手动操作方式，油管可以任购加长，附快速接头，可加装压力表(选购) 压力可保持中间停止，内部设计高压安全保护液压阀
- 油管接头配PT3/8"牙

FEATURES:

- The pump is designed with high-pressure and low-pressure two-stage type, with fast oil output.
- Even if there is no electric fluid to operate, any working pressure and function are the same as the electric type.
- Manual operation mode, the oil pipe can be purchased and lengthened at will, with quick connector, and pressure gauge can be added (optional)
- The pressure can keep the middle stop, and the internal high pressure safety protection hydraulic valve is designed
- Oil pipe joint with pT3/8" thread

产品特点:

- 该泵设计有高、低压两段式，出油量快，即使没有电力液可操作，任何工作压力、功能与电动式相同
- 手动操作方式，油管可以任购加长，附快速接头，可加装压力表(选购) 压力可保持中间停止，内部设计高压安全保护液压阀
- 油管接头配PT3/8"牙

FEATURES:

- The pump is designed with high-pressure and low-pressure two-stage type, with fast oil output.
- Even if there is no electric fluid to operate, any working pressure and function are the same as the electric type.
- Manual operation mode, the oil pipe can be purchased and lengthened at will, with quick connector, and pressure gauge can be added (optional)
- The pressure can keep the middle stop, and the internal high pressure safety protection hydraulic valve is designed
- Oil pipe joint with pT3/8" thread

CP-180 手动式液压泵 Manual hydraulic pump

技术参数 TECHNICAL DATA :	
最大输出压力(Pressure rating):	700/10000kg/cm ² /psi
输出压力 (Pressure rating)	低压(Low) — 高压(High) 800kg/cm ²
每分钟油量 (Oil amount of every minute)	低压(Low) — 高压(High) 2.0cc
储油量(Oil storage):	400cc
重量(Weight):	3.8kg



CP-700-2 手动式液压泵 Manual hydraulic pump

技术参数 TECHNICAL DATA :	
最大输出压力(Pressure rating):	700/10000kg/cm ² /psi
输出压力 (Pressure rating)	低压(Low) 20kg/cm ² 高压(High) 700kg/cm ²
每分钟油量 (Oil amount of every minute)	低压(Low) 12.26cc 高压(High) 2.26cc
储油量(Oil storage):	2800cc
重量(Weight):	15.8kg



CP-390 手动式液压泵 Manual hydraulic pump

技术参数 TECHNICAL DATA :	
最大输出压力(Pressure rating):	700/10000kg/cm ² /psi
输出压力 (Pressure rating)	低压(Low) — 高压(High) 800kg/cm ²
每分钟油量 (Oil amount of every minute)	低压(Low) 10cc 高压(High) 1.8cc
储油量(Oil storage):	400cc
重量(Weight):	7kg



CP-800 手动式液压泵 Manual hydraulic pump

技术参数 TECHNICAL DATA :	
最大输出压力(Pressure rating):	700/10000kg/cm ² /psi
输出压力 (Pressure rating)	低压(Low) 20kg/cm ² 高压(High) 700kg/cm ²
每分钟油量 (Oil amount of every minute)	低压(Low) 12.26cc 高压(High) 2.26cc
储油量(Oil storage):	2800cc
重量(Weight):	18.5kg



CP-700 手动式液压泵 Manual hydraulic pump

技术参数 TECHNICAL DATA :	
最大输出压力(Pressure rating):	700/10000kg/cm ² /psi
输出压力 (Pressure rating)	低压(Low) 20kg/cm ² 高压(High) 700kg/cm ²
每分钟油量 (Oil amount of every minute)	低压(Low) 13cc 高压(High) 2.3cc
储油量(Oil storage):	900cc
重量(Weight):	9.5kg



CP-700 手动式液压泵(铝合金) Manual hydraulic pump(Aluminum alloy)

技术参数 TECHNICAL DATA :	
最大输出压力(Pressure rating):	700/10000kg/cm ² /psi
输出压力 (Pressure rating)	低压(Low) 20kg/cm ² 高压(High) 700kg/cm ²
每分钟油量 (Oil amount of every minute)	低压(Low) 13cc 高压(High) 2.3cc
储油量(Oil storage):	1000cc
重量(Weight):	7kg



安全/ 高效/ 可靠/ 轻便/
SAFETY/ HIGH EFFICIENCY/ TRUSTFUL/ EASIER/



产品特点:

- 使用于分体液压钳、冲切弯等分体液压工具
- 高低压两端输出、油量大
- 压力过载保护装置、避免超压而损坏设备

FEATURES:

- Used in split hydraulic tools such as split hydraulic clamps and punching bends
- High and low pressure output, large oil volume
- Pressure overload protection device to avoid damage to equipment due to overpressure

OPC-700/700AB 便携电动泵 (单回路/双回路)
Portable electric pump

技术参数 TECHNICAL DATA :	
出油形式(Oil support):	OPC-700单孔出油,OPC-700AB
高压压力(High pressure):	70Mpa
低压压力(Low pressure):	7Mpa
高压流量(High pressure flow):	0.7L/min
低压流量(Low pressure flow):	5L/min
电机功率(Power):	1200W
储油量(Oil storage capacity):	2L(出厂自带2L油)
重量(Weight):	10Kg(不含外包装)



ZHQ-700 便携电动泵
Portable electric pump

技术参数 TECHNICAL DATA :	
出油形式(Oil support):	单孔出油(single hole oil support)
高压压力(High pressure):	70Mpa
高压流量(High pressure flow):	0.7L/min
低压流量(Low pressure flow):	5L/min
电机功率(Power):	1200W
电压(Voltage):	220V
转速(Speed):	3700r/min
储油量(Oil storage capacity):	2L
尺寸(Size):	210*160*330mm
重量(Weight):	16/17.5Kg



ZHQ-700D 便携电动泵 (充电式)
Portable electric pump(Battery Portable)

技术参数 TECHNICAL DATA :	
出油形式(Oil support):	单孔出油(single hole oil support)
高压压力(High pressure):	70Mpa
高压流量(High pressure flow):	0.7L/min
低压流量(Low pressure flow):	5L/min
电机功率(Power):	400W
电压(Voltage):	18V
转速(Speed):	1400r/min
储油量(Oil storage capacity):	2.5L
尺寸(Size):	210*160*340mm
重量(Weight):	12.5/22Kg



R14E-F1 便携电动泵
Portable electric pump

技术参数 TECHNICAL DATA :	
出油形式(Oil support):	单孔出油(single hole oil support)
高压压力(High pressure):	70Mpa
高压流量(High pressure flow):	0.32L/min
低压流量(Low pressure flow):	2.6L/min
电机功率(Power):	0.34Kw
电压(Voltage):	220V
转速(Speed):	-
储油量(Oil storage capacity):	3000CC
重量(Weight):	15Kg



GYB-63C 便携电动泵
Portable electric pump

技术参数 TECHNICAL DATA :	
出油形式(Oil support):	单孔出油(single hole oil support)
高压压力(High pressure):	70Mpa
高压流量(High pressure flow):	0.6L/min
低压流量(Low pressure flow):	3.62L/min
电机功率(Power):	600W
电压(Voltage):	220V/3A
转速(Speed):	1400r/min
储油量(Oil storage capacity):	3L
重量(Weight):	15Kg

电动液压泵

ELECTRIC HYDRAULIC PUMP



电动液压泵

ELECTRIC HYDRAULIC PUMP

卓越品质 精心所制

卓越品质 精心所制



GYB-630B 电动液压泵
Electric hydraulic pump

技术参数 TECHNICAL DATA :	
出油形式(Oil support):	单孔出油(single hole oil support)
高压压力(High pressure):	70Mpa
高压流量(High pressure flow):	0.9L/min
低压流量(Low pressure flow):	6L/min
电机功率(Power):	0.75Kw
电压(Voltage):	220V
转速(Speed):	1400r/min
储油量(Oil storage capacity):	7L (可定制)
尺寸(Size):	350×270×480mm



GYB-700A 电动液压泵
Electric hydraulic pump

技术参数 TECHNICAL DATA :	
出油形式(Oil support):	单孔出油(single hole oil support)
高压压力(High pressure):	70Mpa
高压流量(High pressure flow):	0.9L/min
低压流量(Low pressure flow):	6L/min
电机功率(Power):	0.75Kw
电压(Voltage):	220V
转速(Speed):	1400r/min
储油量(Oil storage capacity):	7L (可定制)
尺寸(Size):	470×370×290mm



GYB-700AI 电动液压泵
Electric hydraulic pump

技术参数 TECHNICAL DATA :	
出油形式(Oil support):	双孔出油(Double hole oil support)
高压压力(High pressure):	70Mpa
高压流量(High pressure flow):	1.7L/min
低压流量(Low pressure flow):	7.9L/min
电机功率(Power):	1.5Kw
电压(Voltage):	220V
转速(Speed):	1400r/min
储油量(Oil storage capacity):	30L (可定制)
尺寸(Size):	385×510×630mm



GYB-700AB 电动液压泵
Electric hydraulic pump

技术参数 TECHNICAL DATA :	
出油形式(Oil support):	双孔出油(Double hole oil support)
高压压力(High pressure):	70Mpa
高压流量(High pressure flow):	1.7L/min
低压流量(Low pressure flow):	7.9L/min
电机功率(Power):	1.5Kw
电压(Voltage):	220V
转速(Speed):	1400r/min
储油量(Oil storage capacity):	30L (可定制)
尺寸(Size):	385×510×630mm



GYB-700AII 电动液压泵
Electric hydraulic pump

技术参数 TECHNICAL DATA :	
出油形式(Oil support):	双孔出油(Double hole oil support)
高压压力(High pressure):	70Mpa
高压流量(High pressure flow):	0.9L/min
低压流量(Low pressure flow):	5L/min
电机功率(Power):	0.75Kw
电压(Voltage):	220V
转速(Speed):	1400r/min
储油量(Oil storage capacity):	7L (可定制)
尺寸(Size):	400×300×450mm



GYB-700AB 电动液压泵
Electric hydraulic pump

技术参数 TECHNICAL DATA :	
出油形式(Oil support):	双孔出油(Double hole oil support)
高压压力(High pressure):	70Mpa
高压流量(High pressure flow):	0.9L/min
低压流量(Low pressure flow):	5L/min
电机功率(Power):	0.75Kw
电压(Voltage):	220V
转速(Speed):	1400r/min
储油量(Oil storage capacity):	7L (可定制)
尺寸(Size):	400×300×450mm



GYB-700AIII 电动液压泵
Electric hydraulic pump

技术参数 TECHNICAL DATA :	
出油形式(Oil support):	三孔出油(Three holes for oil support)
高压压力(High pressure):	70Mpa
高压流量(High pressure flow):	0.9L/min
低压流量(Low pressure flow):	5L/min
电机功率(Power):	0.75Kw
电压(Voltage):	220V
转速(Speed):	1400r/min
储油量(Oil storage capacity):	8L (可定制)
尺寸(Size):	400×300×450mm



GYB-700A 电动液压泵
Electric hydraulic pump

技术参数 TECHNICAL DATA :	
出油形式(Oil support):	单孔出油(single hole oil support)
高压压力(High pressure):	70Mpa
高压流量(High pressure flow):	1.7L/min
低压流量(Low pressure flow):	7.9L/min
电机功率(Power):	1.5Kw
电压(Voltage):	220V
转速(Speed):	1400r/min
储油量(Oil storage capacity):	30L (可定制)
尺寸(Size):	385×510×630mm

液压千斤顶

HYDRAULIC CYLINDER



液压千斤顶

HYDRAULIC CYLINDER

产品特点:

- 轻巧紧凑设计用于狭小工作空间
- 烤漆表面增强耐腐蚀能力
- 防尘圈减少污染延长油缸使用寿命
- 轻便容易携带, 油缸平面设有二孔以供固定使用

FEATURES:

- Light and compact design, working in small space
- Paint surface enhances corrosion resistance
- Dust ring reduces pollution and prolongs service life of oil cylinder
- It is light and easy to carry, and the plane of the oil cylinder is provided with two holes for fixed use

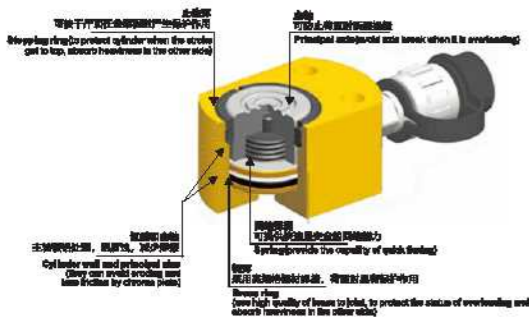

超薄型液压千斤顶 Thin type hydraulic cylinder

技术参数 TECHNICAL DATA :

型号 (Model)	吨位 (Tonnage)	行程 (Stroke)	有效面积 (Effective area)	油缸内径 (Inner diameter of cylinder)	油缸外径 (Outside diameter of cylinder)	本体高度 (Height)	重量 (Weight)	配套泵浦 (Matching pump)
FPY-5	5T	8mm	9.61cm ²	35mm	60×45mm	40mm	0.7kg	CP-180
FPY-10	10T	11mm	16.89cm ²	45mm	80×60mm	47mm	1.6kg	CP-180
FPY-20	20T	12mm	33.16cm ²	65mm	100×80mm	56mm	2.76kg	CP-180
FPY-30	30T	14mm	50.24cm ²	80mm	125×100mm	61mm	5.0kg	CP-700
FPY-50	50T	17mm	78.5cm ²	100mm	155×130mm	71mm	8.5kg	CP-700
FPY-100	100T	18mm	143.06cm ²	135mm	200×170mm	90mm	19kg	CP-700
FPY-200	200T	22mm	201cm ²	192mm	275×246mm	102mm	42.7kg	CP-700-2



多节型液压千斤顶 Multistage hydraulic cylinder

技术参数 TECHNICAL DATA :

型号 (Model)	吨位 (Tonnage)	行程 (Stroke)				油容量 (Oil capacity)	本体高度 (Height)	重量 (Weight)
		1	2	3	总			
DFPY-10	10T	13mm	13mm	-	26mm	22cc	51mm	1.8kg
DFPY-20	20T	16mm	14mm	-	30mm	41cc	57mm	2.8kg
DFPY-30	30T	14mm	21mm	19mm	54mm	68cc	63mm	5.5kg
DFPY-50	50T	20mm	23mm	22mm	65mm	113cc	71mm	9kg
DFPY-100	100T	20mm	24mm	25mm	69mm	225cc	87mm	20.5kg



短型液压千斤顶 Short hydraulic jack

技术参数 TECHNICAL DATA :

型号 (Model)	吨位 (Tonnage)	行程 (Stroke)	本体高度 (Height)	外径 (Outer diameter)	内径 (the inside diameter of)	重量 (Weight)	有效面积 (Effective area)	配套泵浦 (Matching pump)
RSC-1050	10T	50mm	100mm	60mm	45mm	2.7kg	15.89cm ²	CP-180
RSC-2050	20T	50mm	105mm	85mm	65mm	5.0kg	33.16cm ²	CP-180
RSC-3050	30T	50mm	108mm	105mm	80mm	7.0kg	50.24cm ²	CP-700
RSC-5050	50T	50mm	110mm	120mm	100mm	9.9kg	78.5cm ²	CP-700
RSC-10050	100T	50mm	120mm	170mm	135mm	23.0kg	143.06cm ²	CP-700
RSC-20050	200T	50mm	151mm	248mm	196.3mm	52.0kg	302.5cm ²	CP-700-2



长型液压千斤顶 Long hydraulic jack

技术参数 TECHNICAL DATA :

型号 (Model)	吨位 (Tonnage)	行程 (Stroke)	本体高度 (Height)	外径 (Outer diameter)	内径 (the inside diameter of)	重量 (Weight)	有效面积 (Effective area)	配套泵浦 (Matching pump)
RSC-10100	10T	100mm	160mm	60mm	46mm	3.5kg	15.89cm ²	CP-180
RSC-20100	20T	100mm	156mm	85mm	65mm	9.0kg	33.16cm ²	CP-700
RSC-30100	30T	100mm	180mm	105mm	80mm	12.5kg	50.24cm ²	CP-700
RSC-50100	50T	100mm	185mm	120mm	100mm	12.6kg	78.5cm ²	CP-700-2
RSC-100100	100T	100mm	170mm	170mm	135mm	29.5kg	143.06cm ²	CP-700-2

液压千斤顶 HYDRAULIC CYLINDER



液压千斤顶 HYDRAULIC CYLINDER

卓越品质 精心所制

卓越品质 精心所制



加长型液压千斤顶 Extended hydraulic jack

技术参数 TECHNICAL DATA :

型号 (Model)	吨位 (Tonnage)	行程 (Stroke)	本体高度 (Height)	外径 (Outer diameter)	内径 (the inside diameter of)	重量 (Weight)	有效面积 (Effective area)	配套泵浦 (Matching pump)
RSC-10T150	10T	150mm	200mm	80mm	45mm	4.3kg	15.89cm ²	CP-700
RSC-20T150	20T	150mm	205mm	85mm	65mm	13.0kg	33.18cm ²	CP-700
RSC-30T150	30T	150mm	210mm	105mm	80mm	17.5kg	50.24cm ²	CP-700
RSC-50T150	50T	150mm	215mm	120mm	100mm	16.1kg	78.5cm ²	CP-700-2
RSC-100T150	100T	150mm	220mm	170mm	136mm	36.5kg	143.06cm ²	CP-700-2



中空液压千斤顶 Hollow hydraulic cylinder

技术参数 TECHNICAL DATA :

型号 (Model)	吨位 (Tonnage)	行程 (Stroke)	本体高度 (Height)	孔径 (Aperture)	突出高度 (Sallet height)	外径 (Outer diameter)	内径 (the inside diameter of)	主轴外径 (Spindle diameter)	重量 (Weight)	配套泵浦 (Matching pump)
RCH-2050	20T	50mm	175mm	28mm	12mm	88mm	78mm	53mm	8kg	CP-700
RCH-20100	20T	100mm	255mm	28mm	12mm	88mm	78mm	53mm	11kg	CP-700
RCH-3050	30T	50mm	185mm	34mm	12mm	120mm	92mm	65mm	12.3kg	CP-700
RCH-30100	30T	100mm	260mm	34mm	12mm	120mm	92mm	65mm	16.8kg	CP-700
RCH-5050	50T	50mm	231mm	55mm	12mm	170mm	135mm	94mm	29.4kg	CP-700-2
RCH-50100	50T	100mm	300mm	55mm	12mm	170mm	135mm	94mm	37.3kg	CP-700-2
RCH-100T75	100T	75mm	285mm	80mm	12mm	220mm	178mm	129mm	60.3kg	CP-700-2

产品特点:

- 适合需要长行程的顶升操作
- 表面耐腐蚀处理, 光泽亮丽不易生锈
- 单作用, 加载加程
- 各型号配ZG3/8"公接头与防尘帽

FEATURES:

- Suitable for jacking operations that require a long trip
- Surface corrosion resistance treatment, bright luster is not easy to rust
- Single action, load extension
- Each model equipped with ZG 3/8 " public connector and dust cap



多节通用型液压千斤顶 Multi-section universal hydraulic jack

技术参数 TECHNICAL DATA :

型号 (Model)	吨位 (Tonnage)	行程 (Stroke)	外口 (Outer diameter)	内径 (Bore size)	主轴直径 (Spindle diameter)	本体高度 (Height)	伸长后高度 (Height after elongation)	油液容量 (Use of oil)	受压面积 (Compression area)	重量 (Weight)
DFPY-20	20T	100mm	88mm	65mm	54mm	106mm	205mm	0.2L	22.9mm ²	4.8kg
DFPY-30	30T	100mm	105mm	75mm	68mm	108mm	208mm	0.3L	31mm ²	7kg
DFPY-50	50T	150mm	128mm	100mm	85mm	112mm	262mm	0.8L	58mm ²	9.5kg
DFPY-100	100T	150mm	175mm	135mm	110mm	112mm	272mm	0.8L	95mm ²	22kg
DFPY-20	20T	200mm	88mm	65mm	54mm	155mm	355mm	0.5L	22mm ²	7kg
DFPY-30	30T	200mm	107mm	75mm	68mm	162mm	362mm	0.8L	31mm ²	9.8kg
DFPY-50	50T	300mm	128mm	100mm	85mm	212mm	512mm	2.0L	58.7mm ²	9.5kg
DFPY-100	100T	300mm	177mm	135mm	110mm	272mm	272mm	3.0L	95mm ²	22kg

双回路液压千斤顶 Double-circuit hydraulic jack

技术参数 TECHNICAL DATA :

型号 (Model)	吨位 (Tonnage)	行程 (Stroke)	本体高度 (Height)	外径 (Outer diameter)	内径 (Bore size)	活塞直径 (Piston diameter)	重量 (Weight)
RSC-10200	10T	200mm	290mm	85mm	45mm	35mm	5.5kg
RSC-10300	10T	300mm	390mm	85mm	45mm	35mm	-
RSC-10400	10T	400mm	490mm	85mm	45mm	35mm	-
RSC-20200	20T	200mm	300mm	80mm	60mm	40mm	9.8kg
RSC-20300	20T	300mm	400mm	80mm	60mm	40mm	-
RSC-20400	20T	400mm	500mm	80mm	60mm	40mm	-
RSC-30200	30T	200mm	305mm	110mm	70mm	55mm	21kg
RSC-30300	30T	300mm	405mm	110mm	70mm	55mm	29kg
RSC-50200	50T	200mm	315mm	130mm	90mm	75mm	28kg
RSC-50300	50T	300mm	415mm	130mm	90mm	75mm	32kg
RSC-50400	50T	400mm	515mm	130mm	90mm	75mm	-
RSC-100200	100T	200mm	360mm	170mm	130mm	100mm	37kg
RSC-100300	100T	300mm	460mm	170mm	130mm	100mm	66kg
RSC-150200	150T	200mm	350mm	218mm	165mm	115mm	88kg
RSC-150300	150T	300mm	450mm	218mm	165mm	115mm	-
RSC-200200	200T	200mm	360mm	240mm	185mm	135mm	88kg
RSC-200300	200T	300mm	460mm	240mm	185mm	135mm	-
RSC-300200	300T	200mm	400mm	300mm	235mm	200mm	-
RSC-300300	300T	300mm	500mm	300mm	235mm	200mm	-



法兰扩张器 FLANGE EXPANDER



消防设备 FIRE EQUIPMENT

卓越品质 精心所制

卓越品质 精心所制



FS-14 整体式法兰扩张器 Integral flange expander

技术参数 TECHNICAL DATA :	
出力(Output):	10T
顶部间隙(Top clearance):	6mm
最大分距(Max.separation distance):	85mm
油量容积(Oil volume):	70cm ³
重量(Weight):	15kg



FSH-14 分体式法兰扩张器 Split flange expander

技术参数 TECHNICAL DATA :	
出力(Output):	14T
顶部间隙(Top clearance):	8mm
最大分距(Max.separation distance):	81mm
油量容积(Oil volume):	视配件油量而定
重量(Weight):	11kg



KJI-20CB 消防钳 Fire tongs

技术参数 TECHNICAL DATA :	
最大开口距离(Max.opening distance):	≤160mm
额定工作压力(Fixed work stress):	83mm
最大剪切能力(Q235材料)(Max.cutting capacity):	10mm(钢板)Φ20mm(圆钢)
剪切力(Shear force):	18T
扩张力(Expansion force):	5.5T
扩张距离(Expansion distance):	150mm
额定扩张力(Rated expansion force):	24KN
空载开打次数(No-load opening and suppression times):	≤9次
空载闭合打次数(No-load closing and pressing times):	≤11次
手柄力(Handle force):	≤300N
重量(Weight):	15Kg



BC-300-695 充电式消防剪扩钳 Battery fire shear clamp

技术参数 TECHNICAL DATA :	
最大切口(Max.cut mouth):	205mm
最大切割力(Max.cutting force):	313.8KN
中间切割力(Intermediate cutting force):	115.7KN
最大扩张距离(Max.expansion distance):	300mm
最大扩张力(Max.expansion):	135.3KN(10.6t)
尖端扩张力(Cutting-edge expansion force):	51KN(4T)
最大内压力(Max.internal pressure):	44Mpa
电池电压(Voltage):	18V
电池容量(Capacity):	4.0Ah
配件 ACCESSORIES :	
电池(Battery):	2块(PCS)
充电器(Charger):	1个(PC)



FSM-8 机械式法兰扩张器 Mechanical flange expander

技术参数 TECHNICAL DATA :	
出力(Output):	8T (72KN)
顶部间隙(Top clearance):	6mm
最大分距(Max.separation distance):	81mm
重量(Weight):	8.5kg



YQ-30 整体式法兰扩张器 Integral flange expander

技术参数 TECHNICAL DATA :	
吨位(Tonnage):	≥8T
最大张开距离(Max.opening distance):	45mm
顶部厚度(Top thickness):	11mm
长度(Length):	410mm
最大扩张距离(Max.expansion distance):	30mm
重量(Weight):	4kg



破拆工具组5件套
Demolition tool set 5-piece set

技术参数 TECHNICAL DATA :	
小型扩张器(Small expander):	额定扩张力140KN,最大扩张距离81mm
强力开门器(Powerful door opener):	最大驱动力100KN,活套行程150mm
CP-180手动泵(CP-180 manual pump):	高压压力60kg/cm ² ,储油量400cc
美国史丹利组合撬棍(Combination crowbar):	撬多种结构的门和锁
钢剪(Steel Shear):	可剪断直径16mm的钢筋



液压球头拆卸器
Hydraulic ball joint remover

产品特点:

- 液压式球头拆卸系统针对于重型车辆及机械转向球头拆卸作业
- 拆卸一只球头只需十几秒(手动),是快速专业的维修工具

FEATURES:

- The hydraulic ball joint disassembly system is designed for heavy vehicles and mechanical steering ball joint disassembly operations
- It only takes ten seconds to disassemble a ball head (manually), which is a fast and professional repair tool



YQ-55 整体式法兰扩张器 Integral flange expander

技术参数 TECHNICAL DATA :	
吨位(Tonnage):	≥12T
最大张开距离(Max.opening distance):	60mm
顶部厚度(Top thickness):	11mm
长度(Length):	510mm
最大扩张距离(Max.expansion distance):	55mm
重量(Weight):	6kg



YQ-30 分体式法兰扩张器 Split flange expander

技术参数 TECHNICAL DATA :	
吨位(Tonnage):	8T
最大张开距离(Max.opening distance):	58mm
顶部厚度(Top thickness):	11mm
最大扩张距离(Max.expansion distance):	20mm
重量(Weight):	3.7kg

液压线缆剪

HYDRAULIC CABLE CUTTER



液压线缆剪

HYDRAULIC CABLE CUTTER

产品特点:

- 坚硬的弹簧钢刀片, 经热处理
- 二段高速、低压、进油迅速, 操作容易回油方便
- 当压力到达700kg/cm²(12T)时所设计安全保护装置, 会有咔嚓声警告操作者, 停止动作

FEATURES:

- Hard spring steel blade, heat-treated
- Two-stage high-speed, low-pressure, fast oil intake, easy operation and convenient oil return
- The safety protection device is designed when the pressure reaches 700kg/cm² (12T).
- There will be a clicking sound to warn the operator and stop the action



CPC-SERIES 整体式液压线缆剪

Hydraulic cable cutter

技术参数 TECHNICAL DATA:

型号 (Model)	出力 (Output)	剪切范围 (Cutting range)	尺寸 (Size)	重量 (Weight)	包装 (Package)
CPC-60	7T	≤Φ50mm 铜铝电缆 & 铠装电缆 (Cu-Al cable & Armored cable)	610×170×106mm	6kg	纸箱
CPC-75	8T	≤Φ75mm 铜铝电缆 & 铠装电缆 (Cu-Al cable & Armored cable)	770×185×110mm	9.2kg	纸箱
CPC-85	8T	≤Φ85mm 铜铝电缆 & 铠装电缆 (Cu-Al cable & Armored cable)	770×185×110mm	9.2kg	纸箱
CPC-95	10T	≤Φ95mm 铜铝电缆 & 铠装电缆 (Cu-Al cable & Armored cable)	825×180×110mm	10kg	纸箱

CPC-20A 整体式液压线缆剪

Hydraulic cable cutter

技术参数 TECHNICAL DATA:

出力 (Output):	6T
长度 (Length):	420mm
重量 (Weight):	3.6kg
铜铝电缆 (Cu-Al cable):	≤Φ20mm
钢芯铝绞线 (ACSR):	≤Φ18mm
钢丝绳 (Wire rope):	≤Φ20mm
包装 (Package):	塑料箱



CPC-SERIES 分体式液压线缆剪

Hydraulic cable cutter

技术参数 TECHNICAL DATA:

型号 (Model)	出力 (Output)	剪切范围 (Cutting range)	尺寸 (Size)	重量 (Weight)	包装 (Package)
CPC-50	7T	≤Φ50mm 铜铝电缆 & 铠装电缆 (Cu-Al cable & Armored cable)	378×140×102mm	6.5kg	纸箱
CPC-75	8T	≤Φ75mm 铜铝电缆 & 铠装电缆 (Cu-Al cable & Armored cable)	445×193×106mm	6.5kg	纸箱
CPC-85	10T	≤Φ85mm 铜铝电缆 & 铠装电缆 (Cu-Al cable & Armored cable)	445×193×106mm	12.1kg	纸箱
CPC-95	10T	≤Φ95mm 铜铝电缆 & 铠装电缆 (Cu-Al cable & Armored cable)	475×193×105mm	13.5kg	纸箱
CPC-100	11T	≤Φ100mm 铜铝电缆 & 铠装电缆 (Cu-Al cable & Armored cable)	590×260×110mm	14.5kg	木箱
CPC-132	12T	≤Φ132mm 铜铝电缆 & 铠装电缆 (Cu-Al cable & Armored cable)	685×260×110mm	15.8kg	木箱



CPC-65C/105C/120C/135C/150C 分体式液压线缆剪

Hydraulic cable cutter

技术参数 TECHNICAL DATA:

型号 (Model)	出力 (Output)	剪切范围 (Cutting range)	总长 (Total length)	刀头长 (Length of cutter head)	重量 (Weight)
CPC-65C	60KN	≤Φ65mm 铜铝电缆 & 铠装电缆 (Cu-Al cable & Armored cable)	430mm	190mm	6.5kg
CPC-105C	120KN	≤Φ105mm 铜铝电缆 & 铠装电缆 (Cu-Al cable & Armored cable)	470mm	215mm	7.7kg
CPC-120C	120KN	≤Φ120mm 铜铝电缆 & 铠装电缆 (Cu-Al cable & Armored cable)	500mm	230mm	8.5kg
CPC-135C	210KN	≤Φ135mm 铜铝电缆 & 铠装电缆 (Cu-Al cable & Armored cable)	540mm	-	11.0kg
CPC-150C	284KN	≤Φ150mm 铜铝电缆 & 铠装电缆 (Cu-Al cable & Armored cable)	560mm	-	12.6kg

棘轮线缆剪 RATCHET CABLE CUTTER



棘轮线缆剪 RATCHET CABLE CUTTER

卓越品质 精心所制

卓越品质 精心所制



J140

技术参数 TECHNICAL DATA :						
尺寸(Size):	346(伸长Lengthen)×38mm					
重量(Weight):	1.1kg					
包装(Package):	帆布袋(Fabric bag)					
剪切范围(Cutting range):	≤Φ30mm铜芯铠装电缆(Cu-Al core armored cable) ≤300mm铝导线(Al-Cu wire)					
铜包电缆 Cu-Al cable	铠装电缆 Armored cable	海底电缆 Seabed cable	钢芯铝绞线 ACSR	钢绞线 Steel wire ropes	预绞丝 Preformed steel wire	钢芯铝绞线 Aluminum steel bar or disk
✓	✓	✗	✗	✗	✗	✗



J152

技术参数 TECHNICAL DATA :						
尺寸(Size):	387(伸长Lengthen)×568×165×54mm					
重量(Weight):	2.8kg					
包装(Package):	帆布袋(Fabric bag)					
剪切范围(Cutting range):	≤Φ50mm铜芯铠装电缆(Cu-Al core armored cable)					
铜包电缆 Cu-Al cable	铠装电缆 Armored cable	海底电缆 Seabed cable	钢芯铝绞线 ACSR	钢绞线 Steel wire ropes	预绞丝 Preformed steel wire	钢芯铝绞线 Aluminum steel bar or disk
✓	✓	✗	✗	✗	✗	✗



J175

技术参数 TECHNICAL DATA :						
尺寸(Size):	416(伸长Lengthen)×587×200×65mm					
重量(Weight):	3.8kg					
包装(Package):	帆布袋(Fabric bag)					
剪切范围(Cutting range):	≤Φ78mm铜芯铠装电缆(Cu-Al core armored cable) 3600通信电缆(Communication Cable)					
铜包电缆 Cu-Al cable	铠装电缆 Armored cable	海底电缆 Seabed cable	钢芯铝绞线 ACSR	钢绞线 Steel wire ropes	预绞丝 Preformed steel wire	钢芯铝绞线 Aluminum steel bar or disk
✓	✓	✗	✗	✗	✗	✗



J195

技术参数 TECHNICAL DATA :						
尺寸(Size):	448(伸长Lengthen)×620×248×66mm					
重量(Weight):	5.7kg					
包装(Package):	帆布袋(Fabric bag)					
剪切范围(Cutting range):	剪切Φ186mm或Φ96mm以下铜芯铠装电缆(Cu-Al core armored cable)					
铜包电缆 Cu-Al cable	铠装电缆 Armored cable	海底电缆 Seabed cable	钢芯铝绞线 ACSR	钢绞线 Steel wire ropes	预绞丝 Preformed steel wire	钢芯铝绞线 Aluminum steel bar or disk
✓	✓	✗	✗	✗	✗	✗

J100

技术参数 TECHNICAL DATA :						
尺寸(Size):	482(伸长Lengthen)×855×270×69mm					
重量(Weight):	8.2kg					
包装(Package):	帆布袋(Fabric bag)					
剪切范围(Cutting range):	剪切Φ300mm或Φ100mm以下铜芯铠装电缆(Cu-Al core armored cable)					
铜包电缆 Cu-Al cable	铠装电缆 Armored cable	海底电缆 Seabed cable	钢芯铝绞线 ACSR	钢绞线 Steel wire ropes	预绞丝 Preformed steel wire	钢芯铝绞线 Aluminum steel bar or disk
✓	✓	✗	✗	✗	✗	✗



J130

技术参数 TECHNICAL DATA :						
尺寸(Size):	624(伸长Lengthen)×693×328×69mm					
重量(Weight):	8.7kg					
包装(Package):	帆布袋(Fabric bag)					
剪切范围(Cutting range):	剪切Φ416mm或Φ130mm以下铜芯铠装电缆(Cu-Al core armored cable)					
铜包电缆 Cu-Al cable	铠装电缆 Armored cable	海底电缆 Seabed cable	钢芯铝绞线 ACSR	钢绞线 Steel wire ropes	预绞丝 Preformed steel wire	钢芯铝绞线 Aluminum steel bar or disk
✓	✓	✗	✗	✗	✗	✗



J160

技术参数 TECHNICAL DATA :						
尺寸(Size):	660(伸长Lengthen)×735×390×62mm					
重量(Weight):	11.1kg					
包装(Package):	帆布袋(Fabric bag)					
剪切范围(Cutting range):	剪切Φ536mm或Φ160mm以下铜芯铠装电缆(Cu-Al core armored cable)					
铜包电缆 Cu-Al cable	铠装电缆 Armored cable	海底电缆 Seabed cable	钢芯铝绞线 ACSR	钢绞线 Steel wire ropes	预绞丝 Preformed steel wire	钢芯铝绞线 Aluminum steel bar or disk
✓	✓	✗	✗	✗	✗	✗

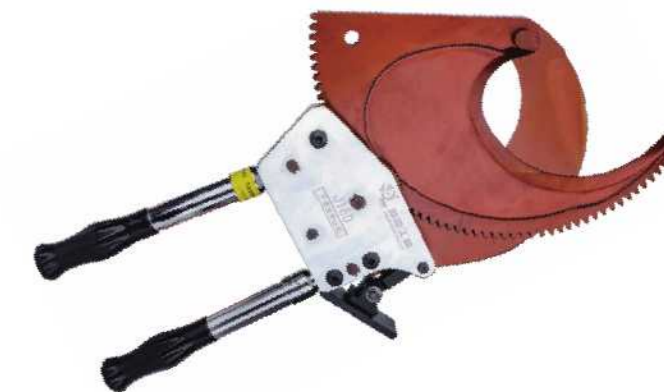

棘轮线缆剪

RATCHET CABLE CUTTER



棘轮线缆剪

RATCHET CABLE CUTTER

卓越品质 精心所制

卓越品质 精心所制



TCR-500S

技术参数 TECHNICAL DATA :	
尺寸(Size):	240(伸长Lengthen290)mm
重量(Weight):	0.9kg
包装(Package):	吸塑(Blistar)
剪切范围(Cutting range):	≤Φ40mm铜铝线(Cu-Al wire) ≤500mm ² 铝线(Al wire) ≤400mm ² 铜线(Cu wire)



J40A

技术参数 TECHNICAL DATA :	
尺寸(Size):	255×125×38mm
重量(Weight):	0.96kg
包装(Package):	吸塑(Blistar)
剪切范围(Cutting range):	≤Φ40mm/300mm ² 铜铝电缆(Cu-Al cable)



XD-520A

技术参数 TECHNICAL DATA :	
尺寸(Size):	310(伸长Lengthen420)×140×55mm
重量(Weight):	1.9kg
包装(Package):	帆布袋(Fabric bag)
剪切范围(Cutting range):	600mm以下铜铝芯铝绞线 Φ32mm以下铜芯电缆 100mm以下钢绞线 Φ12mm以下钢筋 Φ8-16mm钢丝绳

铜铝电缆 Cu-Al cable	铠装电缆 Armored cable	海底电缆 Subsea cable	铜芯铝绞线 ACSR	铜绞线 Steel wire rope	钢绞线 Prestressed steel wire	钢芯铝绞线 Aluminum steel core cable
<input checked="" type="checkbox"/>	<input checked="" type="checkbox"/>	<input checked="" type="checkbox"/>	<input checked="" type="checkbox"/>	<input checked="" type="checkbox"/>	<input checked="" type="checkbox"/>	<input checked="" type="checkbox"/>



XD-75A

技术参数 TECHNICAL DATA :	
尺寸(Size):	416(伸长Lengthen587)×200×55mm
重量(Weight):	3.5kg
包装(Package):	帆布袋(Fabric bag)
剪切范围(Cutting range):	剪切3×120mm ² 或Φ75mm以下铜铝芯铝绞线 (Cu-Al core armored cable)

铜铝电缆 Cu-Al cable	铠装电缆 Armored cable	海底电缆 Subsea cable	铜芯铝绞线 ACSR	铜绞线 Steel wire rope	钢绞线 Prestressed steel wire	钢芯铝绞线 Aluminum steel core cable
<input checked="" type="checkbox"/>	<input checked="" type="checkbox"/>	<input checked="" type="checkbox"/>	<input checked="" type="checkbox"/>	<input checked="" type="checkbox"/>	<input checked="" type="checkbox"/>	<input checked="" type="checkbox"/>



J13

技术参数 TECHNICAL DATA :	
尺寸(Size):	345(伸长Lengthen514)×125×48mm
重量(Weight):	1.9kg
包装(Package):	帆布袋(Fabric bag)
剪切范围(Cutting range):	≤720mm ² 铜芯铝绞线(ACSR) ≤150mm ² 钢绞线(Steel strand)



J25

技术参数 TECHNICAL DATA :	
尺寸(Size):	565(伸长Lengthen745)×130×80mm
重量(Weight):	2.8kg
包装(Package):	帆布袋(Fabric bag)
剪切范围(Cutting range):	≤800mm ² 铜芯铝绞线(ACSR) ≤150mm ² 钢绞线(Steel strand)



XD-95A

技术参数 TECHNICAL DATA :	
尺寸(Size):	426(伸长Lengthen465)×238×90mm
重量(Weight):	6.3kg
包装(Package):	帆布袋(Fabric bag)
剪切范围(Cutting range):	Φ95mm以下铜铝芯铝绞线 (Cu-Al core armored cable)

铜铝电缆 Cu-Al cable	铠装电缆 Armored cable	海底电缆 Subsea cable	铜芯铝绞线 ACSR	铜绞线 Steel wire rope	钢绞线 Prestressed steel wire	钢芯铝绞线 Aluminum steel core cable
<input checked="" type="checkbox"/>	<input checked="" type="checkbox"/>	<input checked="" type="checkbox"/>	<input checked="" type="checkbox"/>	<input checked="" type="checkbox"/>	<input checked="" type="checkbox"/>	<input checked="" type="checkbox"/>



XD-120A

技术参数 TECHNICAL DATA :	
尺寸(Size):	590(伸长Lengthen675)×280×70mm
重量(Weight):	8.5kg
包装(Package):	帆布袋(Fabric bag)
剪切范围(Cutting range):	剪切3×400mm ² 或Φ120mm以下铜铝芯铝绞线 (Cu-Al cable)

铜铝电缆 Cu-Al cable	铠装电缆 Armored cable	海底电缆 Subsea cable	铜芯铝绞线 ACSR	铜绞线 Steel wire rope	钢绞线 Prestressed steel wire	钢芯铝绞线 Aluminum steel core cable
<input checked="" type="checkbox"/>	<input checked="" type="checkbox"/>	<input checked="" type="checkbox"/>	<input checked="" type="checkbox"/>	<input checked="" type="checkbox"/>	<input checked="" type="checkbox"/>	<input checked="" type="checkbox"/>



J30

技术参数 TECHNICAL DATA :	
尺寸(Size):	406(伸长Lengthen514)×180×64mm
重量(Weight):	3.4kg
包装(Package):	帆布袋(Fabric bag)
剪切范围(Cutting range):	≤630mm ² 铜芯铝绞线(ACSR) ≤150mm ² 钢绞线(Steel strand)



J50

技术参数 TECHNICAL DATA :	
尺寸(Size):	400(伸长Lengthen570)×168×62mm
重量(Weight):	2.3kg
包装(Package):	帆布袋(Fabric bag)
剪切范围(Cutting range):	≤1440mm ² 铜芯铝绞线(ACSR) ≤150mm ² 钢绞线(Steel strand)

棘轮线缆剪

RATCHET CABLE CUTTER



长臂式手动电缆剪刀

LONG ARM TYPE MANUAL CABLE SCISSORS

卓越品质 精心所制

卓越品质 精心所制



XLI-D-300

技术参数 TECHNICAL DATA :

尺寸(Size): 240mm
 重量(Weight): 1.2kg
 包装(Package): 帆布袋(Fabric bag)
 剪切范围(Cutting range): 300mm²或Φ30mm以下铜铝芯铠装电缆 (Cu-Al core armored cable)

铜铝电缆 Cu-Al cable	铠装电缆 Armored cable	海底电缆 Subsea cable	钢芯铝绞线 ACSR	钢丝绳 Steel wire ropes	预绞丝 Preformed steel wire	钢绞线 Galvanized steel wire
✓	✓	✗	✗	✗	✗	✗



XLI-D-500

技术参数 TECHNICAL DATA :

尺寸(Size): 240(伸长Lengthen280)mm
 重量(Weight): 1.2kg
 包装(Package): 帆布袋(Fabric bag)
 剪切范围(Cutting range): 500mm²或Φ50mm以下铜铝芯铠装电缆 (Cu-Al core armored cable)

铜铝电缆 Cu-Al cable	铠装电缆 Armored cable	海底电缆 Subsea cable	钢芯铝绞线 ACSR	钢丝绳 Steel wire ropes	预绞丝 Preformed steel wire	钢绞线 Galvanized steel wire
✓	✓	✗	✗	✗	✗	✗



CC-SERIES 长臂式手动电缆剪刀 Long arm type manual cable scissors

技术参数 TECHNICAL DATA :

型号 (Model)	剪切范围 (Shear range)	长度 (Length)	包装 (Package)	包装尺寸 (Package dimensions)	重量 (Weight)
CC-100L	100mm ² 以下铜铝电缆(Cu-Al cable)	320mm	纸盒	330×115×40mm	0.7Kg
CC-250L	250mm ² 以下铜铝电缆(Cu-Al cable)	605mm	纸盒	615×170×45mm	1.7Kg
CC-500L	500mm ² 以下铜铝电缆(Cu-Al cable)	820mm	纸盒	820×180×60mm	2.8Kg



XLI-D-300

技术参数 TECHNICAL DATA :

尺寸(Size): 240mm
 重量(Weight): 1.2kg
 包装(Package): 帆布袋(Fabric bag)
 剪切范围(Cutting range): 300mm²或Φ30mm以下铜铝芯铠装电缆 (Cu-Al core armored cable)

铜铝电缆 Cu-Al cable	铠装电缆 Armored cable	海底电缆 Subsea cable	钢芯铝绞线 ACSR	钢丝绳 Steel wire ropes	预绞丝 Preformed steel wire	钢绞线 Galvanized steel wire
✓	✓	✗	✗	✗	✗	✗



CC-325/535

技术参数 TECHNICAL DATA :

尺寸(Size): 260mm
 重量(Weight): 0.7kg
 包装(Package): 吸塑(Blistar)
 剪切范围(Cutting range): CC-325:240mm²以下单股铜铝电缆(Single strand Cu-Al cable)
 CC-535:Φ32mm以下铜铝电缆(Cu-Al cable)

铜铝电缆 Cu-Al cable	铠装电缆 Armored cable	海底电缆 Subsea cable	钢芯铝绞线 ACSR	钢丝绳 Steel wire ropes	预绞丝 Preformed steel wire	钢绞线 Galvanized steel wire
✓	✓	✗	✗	✗	✗	✗



LK-SERIES 长臂式手动电缆剪刀 Long arm type manual cable scissors

技术参数 TECHNICAL DATA :

型号 (Model)	剪切范围 (Shear range)	长度 (Length)	包装 (Package)	包装尺寸 (Package dimensions)	重量 (Weight)
LK-125	100mm ² 以下铜铝电缆(Cu-Al cable)	360mm	纸盒	380×120×30mm	0.8Kg
LK-250	250mm ² 以下铜铝电缆(Cu-Al cable)	600mm	纸盒	650×165×36mm	1.5Kg
LK-500	500mm ² 以下铜铝电缆(Cu-Al cable)	725mm	纸盒	770×190×45mm	3.1Kg

剥线钳

WIRE STRIPPING PLIERS



剥线钳

WIRE STRIPPING PLIERS

卓越品质 精心所制

卓越品质 精心所制



BK50-105

技术参数 TECHNICAL DATA :	
尺寸(Size):	-
重量(Weight):	0.8kg
包装(Package):	帆布袋(Fabric bag)
剥切范围(Peeling range):	适用于直径50-105mm的电缆和半导体, 剥切深度15mm



BXQ-F-55

技术参数 TECHNICAL DATA :	
尺寸(Size):	255×155×40mm
重量(Weight):	1.0kg
包装(Package):	帆布袋(Fabric bag)
剥切范围(Peeling range):	剥切海陆空电缆的绝缘层, 剥切外径直径20-55mm



BX-30

技术参数 TECHNICAL DATA :	
尺寸(Size):	270×80×50mm
重量(Weight):	0.65kg
包装(Package):	帆布袋(Fabric bag)
剥切范围(Peeling range):	适用于10KV高压电缆70-300mm ² 高压单芯电缆外皮剥切



BX-30A 升级版

技术参数 TECHNICAL DATA :	
尺寸(Size):	280×80×50mm
重量(Weight):	0.8kg
包装(Package):	帆布袋(Fabric bag)
剥切范围(Peeling range):	适用于70-300mm ² 绝缘导线或电力电缆剥切末端和中层绝缘层的剥除, 电缆外径直径15-30mm



BX-40A/B

技术参数 TECHNICAL DATA :	
尺寸(Size):	250×85×55mm
重量(Weight):	0.8kg
包装(Package):	塑料箱(plastic box)
剥切范围(Peeling range):	BX-40A: 适用于10KV, 直径20-40mm电缆末端的绝缘层剥除 BX-40B: 适用于10KV, 直径20-40mm电缆末端的半导体层剥除



KBX-65

技术参数 TECHNICAL DATA :	
尺寸(Size):	295×125×70mm
重量(Weight):	1.4kg
包装(Package):	塑料箱(plastic box)
剥切范围(Peeling range):	适用于35KV, 直径35-65mm绝缘层和半导体层剥除



BX-50

技术参数 TECHNICAL DATA :	
尺寸(Size):	335×80×70mm
重量(Weight):	0.8kg
包装(Package):	帆布袋(Fabric bag)
剥切范围(Peeling range):	10KV □ 20KV □ 35KV □ 适用于70-400mm ² 高压单芯电缆的剥除



BH-300A

技术参数 TECHNICAL DATA :	
尺寸(Size):	280×80×55mm
重量(Weight):	0.76kg
包装(Package):	帆布袋(Fabric bag)
剥切范围(Peeling range):	适用于20-300mm ² 绝缘电缆, 架空导线及电缆的绝缘层和中层快速剥切



BK-50

技术参数 TECHNICAL DATA :	
尺寸(Size):	-
重量(Weight):	0.8kg
包装(Package):	帆布袋(Fabric bag)
剥切范围(Peeling range):	适用于10-20KV, 直径10-60mm以下的电缆和半导体剥切厚度达10mm的高压电缆末端的半导体层剥除



BP-400

技术参数 TECHNICAL DATA :	
尺寸(Size):	-
重量(Weight):	0.85kg
包装(Package):	帆布袋(Fabric bag)
剥切范围(Peeling range):	适用于直径30mm以下的铜铝电机, 剥切厚度小于4.5mm



BXQ-Z-40B

技术参数 TECHNICAL DATA :	
尺寸(Size):	-
重量(Weight):	0.85kg
包装(Package):	帆布袋(Fabric bag)
剥切范围(Peeling range):	适用于直径12-40mm的绝缘电缆及电缆绝缘层和中层快速剥切



SBX-30

技术参数 TECHNICAL DATA :	
尺寸(Size):	-
重量(Weight):	0.85kg
包装(Package):	帆布袋(Fabric bag)
剥切范围(Peeling range):	适用于10kv, 35-300mm ² 以下架空导线绝缘层和中层剥除

机械式液压钳

MECHANICAL CRIMPING TOOLS



机械式液压钳

MECHANICAL CRIMPING TOOLS

产品特点:

- 精密的口模材质为SCM-40
- 孔径尺寸精准压接效果佳
- 压接钳用于非焊接的符合标准的电气焊接
- 人体工学设计, 握感舒适, 防电防滑

FEATURES:

- The precision die material is SCM-40
- The aperture size is accurate and the crimping effect is good
- Crimping tools are used for non-welding electrical welding that meets standards
- Ergonomic design, comfortable grip, anti-slip and anti-slip

JY0650 机械式液压钳

Mechanical crimping tools

技术参数 TECHNICAL DATA:	
压接范围(Crimping force):	5-60mm ²
压接形式(Crimping type):	六角圆压
重量(Weight):	1.25Kg
配件 ACCESSORIES:	
模具(Crimping die):	6,10,16,25,35,50mm ²



JY16120 机械式液压钳

Mechanical crimping tools

技术参数 TECHNICAL DATA:	
压接范围(Crimping force):	16-120mm ²
压接形式(Crimping type):	六角圆压
重量(Weight):	4.0Kg
配件 ACCESSORIES:	
模具(Crimping die):	16,25,35,50,75,95,120mm ²



JY35150 机械式液压钳

Mechanical crimping tools

技术参数 TECHNICAL DATA:	
压接范围(Crimping force):	35-150mm ²
压接形式(Crimping type):	六角圆压
重量(Weight):	4.2Kg
配件 ACCESSORIES:	
模具(Crimping die):	35,60,75,95,120,160mm ²



KH-150 机械式液压钳

Mechanical crimping tools

技术参数 TECHNICAL DATA:	
压接范围(Crimping force):	10-120mm ²
压接形式(Crimping type):	点压式压接
长度(Length):	620mm
重量(Weight):	3.2Kg
包装(Package):	纸盒
配件 ACCESSORIES:	
模具(Crimping die):	10,16,25,35,50,70,95,120mm ²

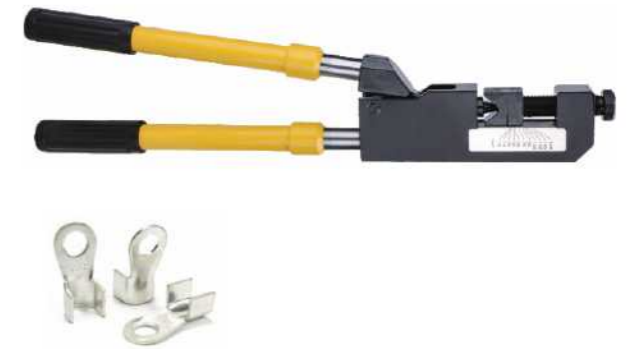

KH-230 机械式液压钳

Mechanical crimping tools

技术参数 TECHNICAL DATA:	
压接范围(Crimping force):	10-240mm ²
压接形式(Crimping type):	点压式压接
长度(Length):	720mm 可伸缩手柄
重量(Weight):	3.7Kg
包装(Package):	纸盒
配件 ACCESSORIES:	
模具(Crimping die):	10,16,25,35,50,70,95,120,150,185,240mm ²



TM-120 机械式液压钳

Mechanical crimping tools

技术参数 TECHNICAL DATA:	
压接范围(Crimping force):	10-120mm ²
压接形式(Crimping type):	点压式压接
长度(Length):	570mm
重量(Weight):	3.2Kg
包装(Package):	纸盒
配件 ACCESSORIES:	
模具(Crimping die):	10,16,25,35,50,70,95,120mm ²

TM-150 机械式液压钳

Mechanical crimping tools

技术参数 TECHNICAL DATA:	
压接范围(Crimping force):	10-150mm ²
压接形式(Crimping type):	点压式压接
长度(Length):	650mm
重量(Weight):	4.0Kg
包装(Package):	纸盒
配件 ACCESSORIES:	
模具(Crimping die):	10,16,25,35,50,70,95,120,160mm ²

管道连接工具

PIPE CONNECTION TOOL



管道连接工具

PIPE CONNECTION TOOL

卓越品质 精心所制

卓越品质 精心所制



PC-1632B 管道连接工具

技术参数 TECHNICAL DATA:

滑紧范围 (Slip tight range)	扩管范围 (Expansion range)	包装尺寸 (Package dimensions)	包装重量 (Package weight)	滑紧模具 (Slide tight mold)	扩管模具 (Expanding mold)
Φ16-Φ32mm	Φ16-Φ32mm	420×340×120mm	6.3Kg	Φ16, Φ20, Φ25, Φ32mm	Φ16, Φ20, Φ25, Φ32mm



PEX-1632 管道连接工具

技术参数 TECHNICAL DATA:

压接范围 (Crimping range)	行程 (stroke)	重量 (Weight)	扩管模具 (Expanding mold)
Φ16-Φ32mm	45mm	8.5Kg	Φ16×2.3, Φ20×2.6, Φ25×3.5, Φ32×4.4mm



HHKG-32 管道连接工具

技术参数 TECHNICAL DATA:

扩管范围(Expansion range):	Φ16-Φ32mm
管材壁厚(Pipe wall thickness):	1.0mm
重量(Weight):	3.5Kg
包装尺寸(Package dimensions):	500×220×65mm
配件ACCESSORIES:	
模具(Crimping dies):	5/8", 3/4", 1", 1 1/4"



模具不可拆卸
(Mold non detachable)

CW-20/25 机械式压管工具

技术参数 TECHNICAL DATA:

出力(Output):	3T
长度(Length):	530mm
重量(Weight):	2.4Kg
包装(Package):	塑料箱(Plastic box)
配件ACCESSORIES:	
模具(Crimping dies):	Φ20/Φ25mm



CW-1632 机械式压管工具

技术参数 TECHNICAL DATA:

出力(Output):	6T
行程(Stroke):	45mm
长度(Length):	580mm
重量(Weight):	4.0Kg(不含包装)
配件ACCESSORIES:	
模具(Crimping dies):	
不锈钢压接(Stainless steel crimping):	Φ16, Φ20, Φ26, Φ32mm
铝塑管压接(Aluminum plastic pipe crimping):	
A模具(Mould):	Φ16, Φ20, Φ26, Φ32mm
B模具(Mould):	Φ16, Φ20, Φ26, Φ32mm



CW-1625 机械式压管工具

技术参数 TECHNICAL DATA:

出力(Output):	3T
长度(Length):	530mm
重量(Weight):	2.35Kg
包装(Package):	塑料箱(Plastic box)
配件ACCESSORIES:	
模具(Crimping dies):	Φ16/Φ20/Φ25mm

试压泵

PRESSURE TEST PUMP



试压泵

PRESSURE TEST PUMP

卓越品质 精心所制

卓越品质 精心所制

25KG 不锈钢试压泵(双球阀泵头) Stainless steel pressure test pump

技术参数 TECHNICAL DATA:	
工作压力(Output):	2.5Mpa
压力(stroke):	25公斤
冲程(Crimpling range):	35mm
重量(Weight):	3.5Kg
外形尺寸(Hydraulic oil):	300×180×290mm



25KG 铁箱试压泵(双球阀铁泵头) Iron box pressure test pump

技术参数 TECHNICAL DATA:	
工作压力(Output):	2.5Mpa
压力(stroke):	25公斤
冲程(Crimpling range):	35mm
重量(Weight):	3.6Kg
外形尺寸(Hydraulic oil):	300×180×300mm

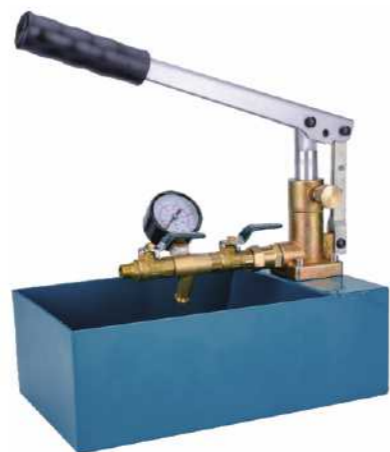

25KG 铁箱试压泵(双球阀铜泵头) Iron box pressure test pump

技术参数 TECHNICAL DATA:	
工作压力(Output):	2.5Mpa
压力(stroke):	25公斤
冲程(Crimpling range):	35mm
重量(Weight):	3.6Kg
外形尺寸(Hydraulic oil):	300×180×300mm



DSY-25



DSY-60/100

DSY-25/60/100 电动试压泵 Electric pressure test pump

技术参数 TECHNICAL DATA:

型号 (Model)	电压 (Voltage)	功率 (Power)	流量 (flow)	工作压力 (Work pressure)	水箱容积 (Water tank volume)	尺寸 (Size)	重量 (Weight)
DSY-25	220V	150W	180L/H	25Kg(2.5Mpa)	7.4L	380×220×130mm	11Kg/14Kg
DSY-80	220V	250W	260L/H	80Kg(8.0Mpa)	25.8L	400×300×270mm	12.5Kg/14Kg
DSY-100	220V	350W	180L/H	100Kg(10Mpa)	25.8L	400×300×290mm	13.5Kg



3DSY-25/40/60/80/100 电动试压泵 Electric pressure test pump

技术参数 TECHNICAL DATA:

型号 (Model)	电压 (Voltage)	功率 (Power)	流量 (flow)	工作压力 (Work pressure)	水箱容积 (Water tank volume)	尺寸 (Size)	重量 (Weight)
3DSY-25	220V/380V	750W	360L/H	25Kg(2.5Mpa)	19L	410×270×55mm	18.4Kg/25Kg
3DSY-40	220V/380V	750W	360L/H	40Kg(4.0Mpa)	19L	410×270×55mm	18.4Kg/25Kg
3DSY-60	220V/380V	750W	360L/H	60Kg(6.0Mpa)	19L	410×270×55mm	18.4Kg/25Kg
3DSY-80	220V/380V	900W	360L/H	80Kg(8.0Mpa)	19L	410×270×55mm	18.4Kg/25Kg
3DSY-100	220V/380V	900W	360L/H	100Kg(10Mpa)	19L	410×270×55mm	18.4Kg/25Kg

液压扭矩扳手

HYDRAULIC TORQUE WRENCH



电力工具

ELECTRIC POWER TOOL



搭配专用电动泵

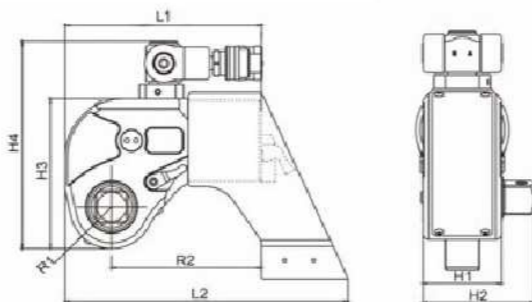

FM-SERIES 驱动型液压扭矩扳手

Drives-type hydraulic torque wrench

技术参数 TECHNICAL DATA:

型号	最小扭矩范围	最大扭矩范围	最小螺栓尺寸	最大螺栓尺寸	重量	结构尺寸								方英寸
						L1	L2	H1	H2	H3	H4	R1	R2	
FM-3	451Nm	4512Nm	M22	M48	4Kg	169mm	242mm	68mm	85mm	127mm	178.5mm	34mm	134mm	1"
FM-5	752Nm	7528Nm	M27	M58	7Kg	202.5mm	283.5mm	80mm	123mm	149mm	198.5mm	38mm	152mm	1-1/2"
FM-8	1078Nm	10780Nm	M30	M64	9.1Kg	216mm	309mm	90mm	134mm	167mm	216.5mm	47mm	171mm	1-1/2"
FM-10	1551Nm	15516Nm	M36	M72	13.1Kg	237.6mm	340.5mm	100mm	142mm	182mm	231.5mm	51mm	174mm	1-1/2"
FM-20	2666Nm	26664Nm	M42	M90	26Kg	299.6mm	466.6mm	120mm	183mm	220mm	289.6mm	59mm	260.6mm	2-1/2"
FM-25	3472Nm	34725Nm	M48	M100	31Kg	313mm	461mm	137mm	200mm	247mm	296.5mm	68mm	250.5mm	2-1/2"
FM-35	4888Nm	48888Nm	M64	M120	45Kg	381.5mm	496.5mm	153mm	216mm	282mm	331.5mm	77mm	271mm	2-1/2"

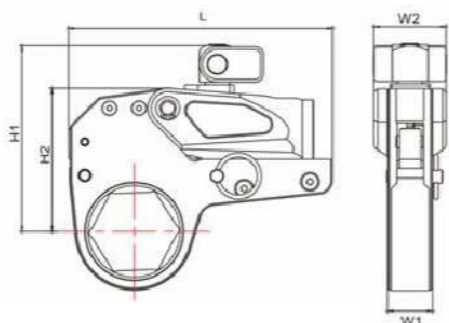

FM-K2/K4/K8/K14 中空型液压扭矩扳手

Hollow-type hydraulic torque wrench

技术参数 TECHNICAL DATA:

驱动头型号	最小扭矩范围	最大扭矩范围	螺母对边 A/F	驱动头重量	工作头重量	结构尺寸				
						L	H1	H2	W1	W2
FM-K2	232	2328Nm	19-55mm	1Kg	1.6Kg	196.4mm	125.9mm	102.3mm	32mm	51mm
	241Nm	2414Nm	60mm	1Kg	1.7Kg	196.4mm	128.6mm	106mm	32mm	51mm
FM-K4	586Nm	5021Nm	34-65mm	2Kg	4.4Kg	246mm	177mm	135.7mm	42mm	66mm
	847Nm	8474Nm	70-80mm	2Kg	4.8Kg	245mm	187mm	145.7mm	42mm	66mm
FM-K8	1094Nm	10941Nm	41-95mm	3.3Kg	8Kg	300mm	207mm	169mm	53mm	83mm
	1177Nm	11774Nm	100-105mm	3.3Kg	8.4Kg	301mm	216mm	178mm	53mm	83mm
FM-K14	1852Nm	18521Nm	60-117mm	5.5Kg	11.6Kg	361mm	239mm	204mm	64mm	99mm



SW-1018 充电式剥线钳

Battery wire stripping pliers

技术参数 TECHNICAL DATA:

剥线范围(Exposure line range):	Φ50-300号线
电池电压(Voltage):	18V
电池容量(Capacity):	4.0Ah
重量(Weight):	2Kg(含电池)
衬套配置(Bushing):	13.2, 14, 14.8, 15.6, 16.4, 17.2, 18, 18.6, 19.6, 20.4, 21.2, 22, 22.8, 23.6, 24.4, 25.2, 26, 26.8, 27.6, 28.4



DC-35 机械式导轨切断机

Mechanical rail cutting machine

技术参数 TECHNICAL DATA:

出力(Contribute):	6T
重量(Weight):	4.5Kg
剪切范围(Shear range):	槽板: 30*3mm, 导轨: 非标35*7.5mm, 扁钢: 35*6.5mm
模具配置(Mold configuration):	切槽机/槽板/导轨(出厂只配一付模具, 其它模具可定制)



CCD 电缆弯线器

Cable bender

技术参数 TECHNICAL DATA:

产品规格(Product specifications):	35-185平方
重量(Weight):	2.7Kg
使用范围(Use range):	适用于10Kv, 35-185平方电缆弯曲



分体式消防自动液压卡钳



三通四通管件接头

大小头

弯头套头



卓越品质 精心所制

卓越品质 精心所制



快插式母接头
PUSH-IN FEMALE CONNECTOR



快插式公接头
PUSH-IN MALE CONNECTOR



ZG3/8母接头
ZG3/8 FEMALE CONNECTOR



ZG3/8公接头
ZG3/8 MALE CONNECTOR



高压油管
HIGH-PRESSURE PIPELINE



防震压力表
SHOCKPROOF PRESSURE GAUGE



电磁阀(单回路)
SOLENOID VALVE (SINGLE CIRCUIT)



电磁阀(单回路)
SOLENOID VALVE (SINGLE CIRCUIT)



电磁阀(双回路)
SOLENOID VALVE (DUAL CIRCUIT)



冲孔机活塞
PUNCHING MACHINE PISTON



冲孔机锁帽
PUNCHING MACHINE LOCK CAP



冲孔机弹簧
PUNCHING MACHINE SPRING



铜芯转子
COPPER CORE ROTOR



CH-60冲孔机模具
PUNCHING MACHINE MOLD



CH-60冲孔机模具(角铁款)
PUNCHING MACHINE MOLD



CH-70冲孔机模具
PUNCHING MACHINE MOLD



CH-70冲孔机模具(角铁款)
PUNCHING MACHINE MOLD



CH-60冲孔机模具(椭圆模)
PUNCHING MACHINE MOLD



CH-70冲孔机模具(椭圆模)
PUNCHING MACHINE MOLD

可定制一字模、椭圆模等
CAN BE CUSTOMIZED FOR A FONT, OVAL MOLD, ETC.